

SPID Elektronik

User manual for controllers

MD-01 / MD-02 / MD-03

for firmware from version 2.0



Table of Contents

Table of Contents	2
General.....	5
Block diagram.....	5
Controller technical data	6
Panels descriptions	6
Front.....	6
Back.....	6
How to connect the controller to the BIG-RAS/HR rotor:.....	8
#1 Connection of Azimuth & Elevation motors:.....	8
Sensors connection	9
#2 Connection of the sensor cable from the rotator to the controller (AZ/EL)	9
Operating	10
NORMAL MODE	10
MOTOR ANGLES.....	11
SPEED CALIBR.....	12
Controller configuration	15
MOTOR CONFIGURATION	16
TEMPLATE	16
Start.....	18
Stop	18
Satellite Mode.....	19
External control (CONTROL xx)	19
Protocol (PROT. xx)	20
Motors setting (SET MOTOR 1, SET MOTOR 2).....	20
STATE	20
TYPE	20

KIND	20
INPUT	21
GEAR	23
MIN ANGLE.....	23
MAX ANGLE.....	24
MAX POWER	24
PULS TIMEOUT	24
Setting RS232 port (SET COM0, SET COM1).....	24
STATE	24
BAUD	24
DATA BITS.....	24
STOP BITS	24
PARITY	24
Setting RS232 virtual port (SET USB COM).....	25
STATE	25
BAUD.....	25
DATA BITS.....	25
STOP BITS	25
PARITY	25
Setting ETHERNET port (SET ETHERNET).....	25
STATE	25
Dimensions:	26
ACCESSORY	29
CABLE CONNECTIONS	31
ETHERNET MODULE v1	39
User installation	39
Configuration	40
ETHERNET MODULE v2	41

User installation	41
Configuration	45
CCM - CURRENT CONTROL MODULE	47
Installation of the CCM module in the MD-01	47
Installation of the CCM module in the MD-02	49
Installation of the CCM module in the MD-03	52
Configuration of CCM module	55
Operating CCM module	56
IMP/HR MODULE	57
User installation	57
COM1 cable for MD-03	60
User installation	60
FIRMWARE UPDATE	62

General

MD-01 / MD-02 / MD-03 units are electronic rotor controllers. They are multifunction devices allowing various combinations of work settings. Single rotors (e.g. two Azimuth rotors), double rotors (one Azimuth / Elevation rotor or one X/Y rotor) can be connected to the controller. The system provides work with DC motors.

From firmware version v2.0 has improved control algorithms,

- supports rotors in a mechanical configuration type X / Y,
- supports the CAN Bus allowing to read operating parameters m.in from absolute encoders and inclinometers (required compatibility of the sensor with the protocol supported by the controller),
- has implemented satellite mode (SATELLITE MODE), dedicated to tracking satellites in LEO orbit, increasing the smooth operation of motors and reducing engine loads, gearboxes and relays (note: at the expense of a slight reduction in accuracy) – only for rotors with HR and CAN Bus sensors,
- optimizes start and stop cycles thanks to the calibration mode of minimum engine power (CALIBRATION).



To verify the installed firmware version before turning on the device, press and hold the F and F2 buttons at the same time, then while holding turn on the device until the software version is displayed. The installed firmware version is also displayed for a few seconds after starting the device.

Block diagram

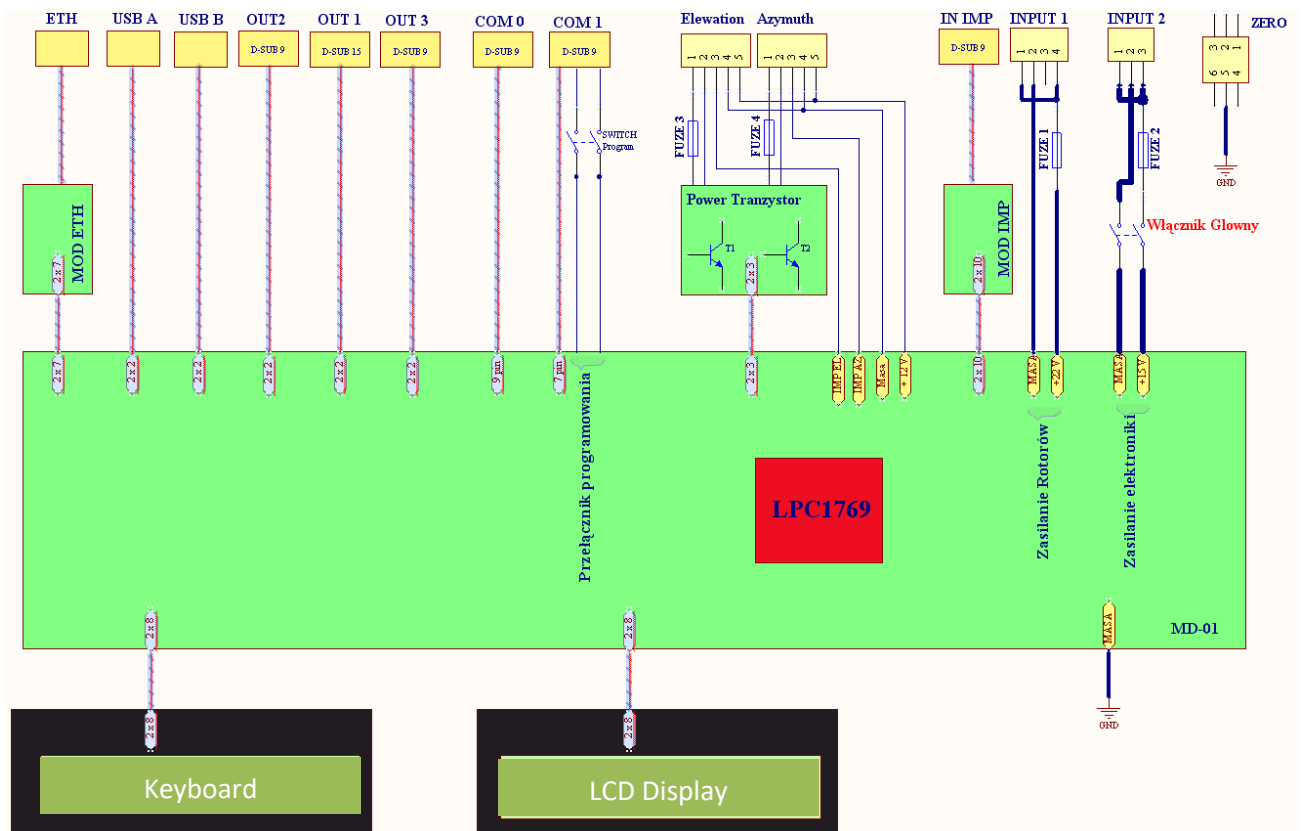

Controller technical data

- controller supply voltage 15 VDC ($I_{max} - 2A$)
- rotor supply voltage standard models 14-18 VDC ($I_{max} - 20A$), BigRAS/HR and SDD 24-30 VDC ($I_{max} - 12A$) or other voltage if specified in the description of the ordered device
- maximum power current of a single motor up to 20 A
- 2 RS232 ports,
- 1 USB host port – not active
- 1 USB device port – visible in the system as a virtual COM port
- 1 RJ45 Ethernet port

Panels descriptions

Front

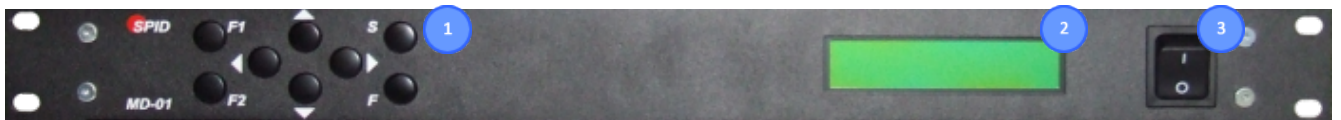

MD-01



MD-02



MD-03

1. Keyboard.
2. LCD screen.
3. On/off switch.

Back

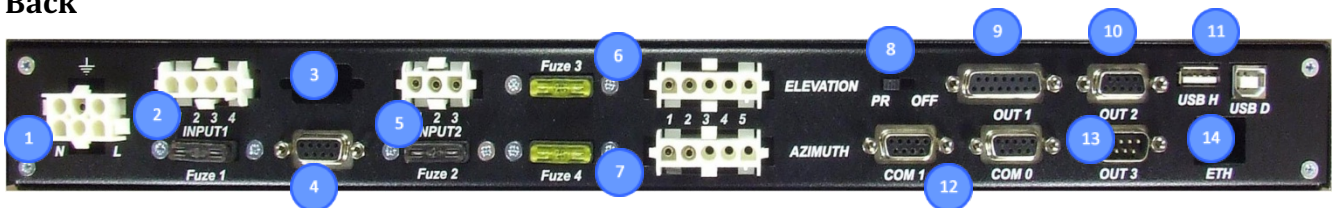

MD-01

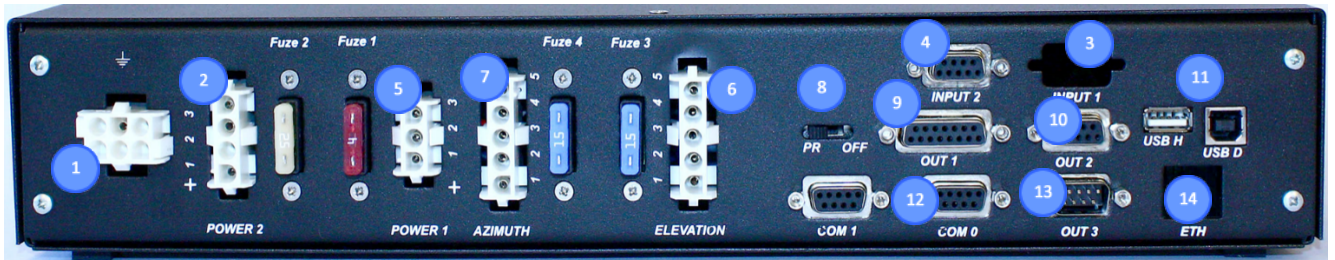

MD-02

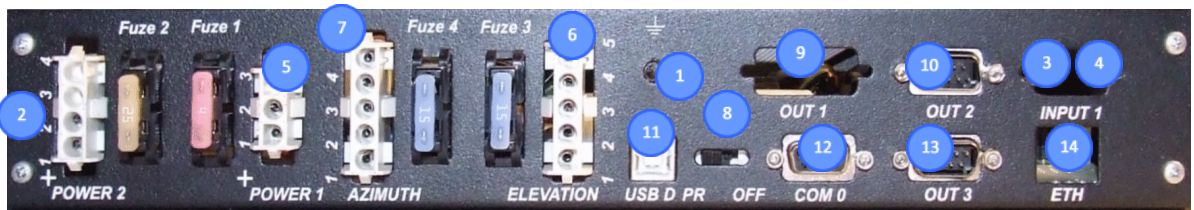

MD-03

1. Input socket for Connecting Ground (rest of NC pins).
2. Power input for Rotor motors (fuse 40A).
3. Socket for connecting modules such as ABS CAN, RS485, RS422 or analog inputs.
4. Pulse input for systems with two HALL sensors.
5. Electronics power input (fuse 2A).
6. Outputs for connecting rotor BIG-RAS Elevation. Motor power pins. Elevation of pins from the engine (3, 4), pins in the controller (1, 2). Each output has its own fuse (20A).
7. Outputs for connecting the BIG-RAS Azimuth Rotor. Motor power pins. Azimuth pins from the motor (1.2), pins in the controller (1, 2). Each output has its own fuse (20A).
8. Switch for updating driver software (FIRMWARE). To update the software, we use COM0 (point 12), and set the switch to the OFF position. The normal operating mode of the controller is when the switch is in the PR position.
9. Universal output – possibility of connecting a module with relays inside the controller. Then the controller will have the function of an antenna switch.
10. I2C output – used to control the SW-01 switch.
11. USB ports – HOST (plug type A) and DEVICE (plug type B).
12. RS232 ports – COM0 and COM1. COM0 is also used to update driver software (see point 8).
13. Mouse input.
14. Ethernet socket RJ 45.

PIN	FUNCTION
1	NC
2	NC
3	NC
4	NC
5	GROUND
6	NC

PIN	FUNCTION
1	U1 + 22 V
2	GROUND
3	NC
4	U1 + 22 V

PIN	FUNCTION
1	WE imp 2 E
2	WE imp 1 E
3	WE imp 2 A
4	WE imp 1 A
5	12 VDC
6	12 VDC
7	12 VDC
8	GROUND
9	GROUND

PIN	FUNCTION
1	MOTOR
2	MOTOR
3	WE IMP
4	GROUND
5	+ 12 VDC



Pinout description at unit's back panel

How to connect the controller to the BIG-RAS/HR rotor:

#1 Connection of Azimuth & Elevation motors:

The rotor is connected to the controller via the supplied plugs (4-Pin), they are used in to power the Azimuth and Elevation motors.



In the controllers in the AZ and EL outputs, pins 1 and 2 are always used to power the motors. Remember to verify the correctness of connecting the polarity of the motor power supply. The pins in the rotor connection box for AZ are numbered 1 and 2, and for the EL pin in the rotor they are numbered 3 and 4.

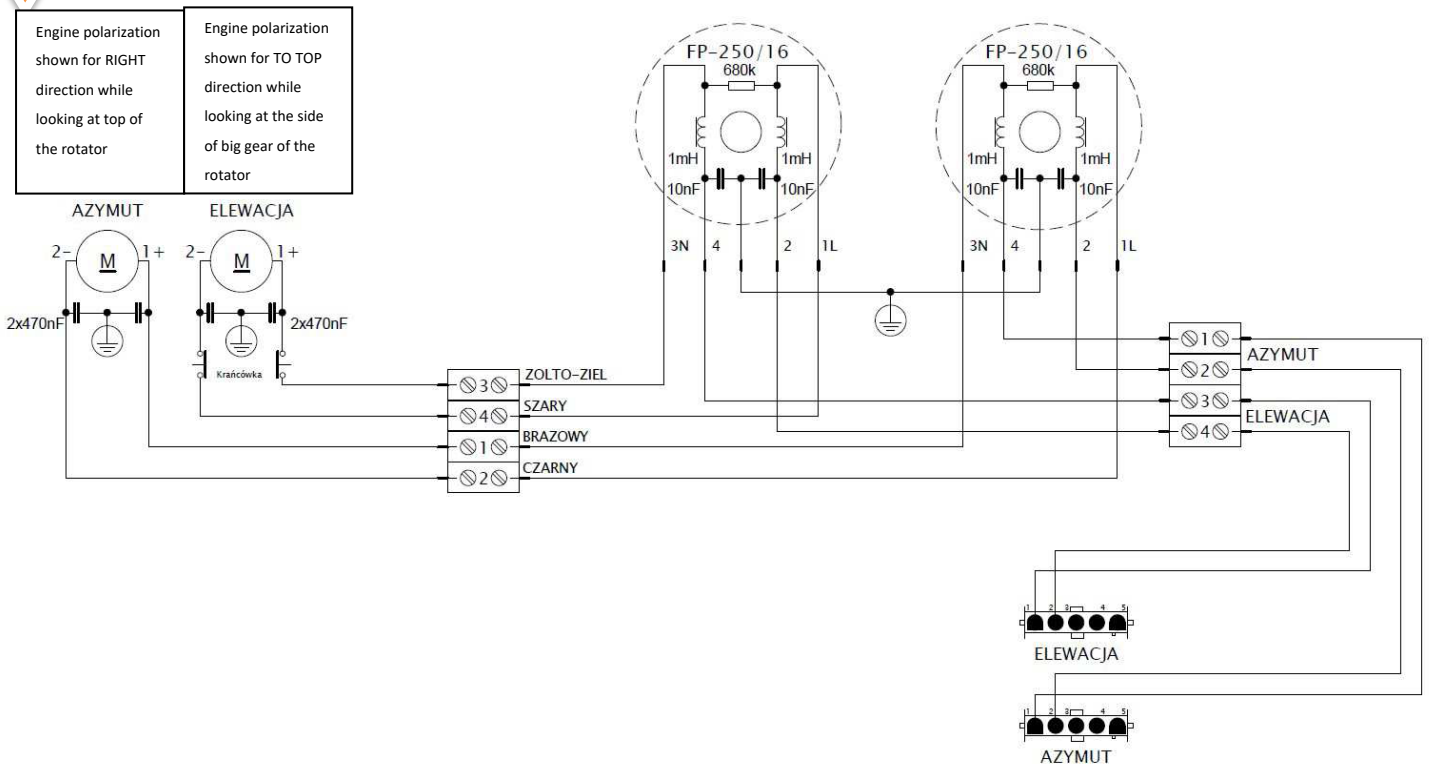

Sensors connection

#2 Connection of the sensor cable from the rotator to the controller (AZ/EL)

The connection from the rotor side is carried out by an eight-pin connector type MIC328, which is located in a PVC box at the rotator, on the back side of the controller there is a nine-pin connector of type DB9. A shielded six-wire cable should be used for connection.



Good shielding and its effective grounding is necessary to protect the rotor and controller from the influence of electromagnetic radiation of the transmitting antennas, otherwise the controller can count false pulses generated by a RF field inducing voltage in the connection cable.

Connection diagram (left MIC328, right WEIPU Sp17):

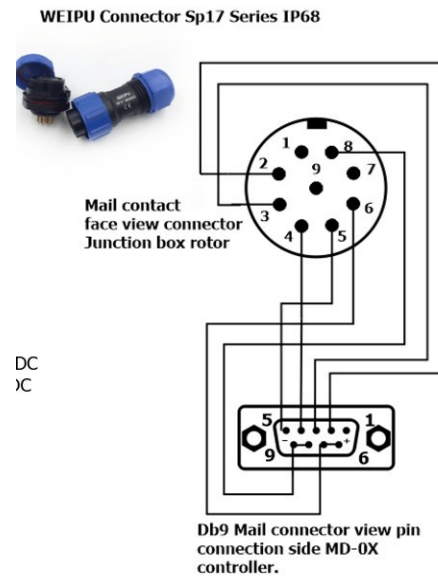
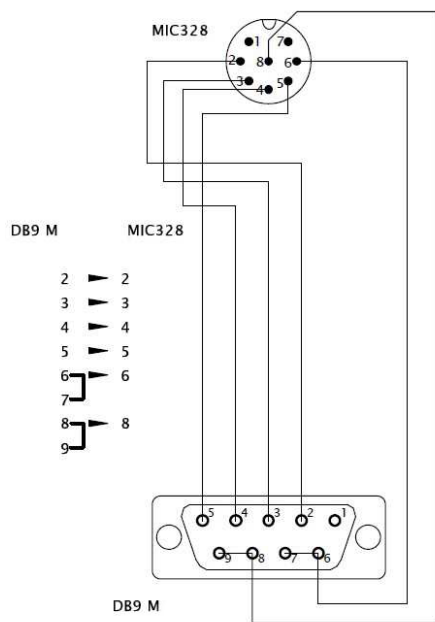

Operating

The controller can be operated using the keyboard located at the front panel or a computer with the appropriate software installed (e.g. PstRotator).

Modes:

- **NORMAL** – standard operating mode



MODE: NORMAL
A1: 0.00 E2: 1.00

- **MOTOR ANGLES** – calibration mode of the actual rotator's position relative to geographical directions,
- **SPEED CALIBR.** – calibration for SOFTLY and SATELLITE modes



MODE: SPEED CALIBR.
LONG S TO START

To change the operating mode, use the [F] button.



Before using the controller with the rotator, start procedure for setting the minimum motor power (MIN POWER) which should be able to move and turn the antenna system:

1. Set the SET MOTOR -> MIN POWER [motors 1 and 2] to 100%.
2. Then go to the parameters SET MOTOR -> MAX POWER to determine the minimum power of the motors, which allows the rotator to move both for AZ and for EL motors [overcoming transmission resistance, boom and antenna weight, etc.]: by reducing the engine power values from 100%, experimentally look for the lowest possible value that allows the engines to move without causing a TIME OUT error. If an error occurs, restart the controller with the main switch and follow the procedure again.
3. After finding the appropriate values for each of the engines, in order to take into account the possibility of other operating resistances (e.g. due to low temperature, wind, nonlinearity of loads in AZ/EL operation, etc.), the margin [e.g. 10-15%, for possible verification in practice] should be taken into account, and the obtained values should be increased accordingly and entered as appropriate parameters for both motors in the parameter (note!) MIN POWER, then return to MAX POWER set to 100% or in the range between MIN POWER and 100%, at the discretion of the user, if he does not expect the rotator to work at full speed.
4. The starting base, for a user who does not want to perform the above procedure, may be MIN POWER 50% and MAX POWER 100% respectively [usually sufficient for standard antenna systems], however, it should be taken into account that such settings will not work optimally and may generate errors (e.g. TIME OUT).
5. Completion of the procedure for setting the minimum engine power (MIN POWER) means that the correct values have been entered for both engines in the MIN POWER and MAX POWER fields. This is the moment when the user can proceed to calibrate the SOFTLY and SATELLITE (SPEED CALIBR.) modes.

NORMAL MODE

In this mode the controller can be operated with the [Right], [Left], [Top] and [Bottom] buttons or by commands send from a PC. The controller supports the communication protocols SPID ROT1, SPID ROT2,

YAESU, which in the settings can be assigned to the selected communication port (COM0, COM1, USB D and ETH). Keyboard function:

- The [Right] and [Left] buttons are used to rotate the antenna in the azimuth plane:
 - direction Right - the antenna rotates clockwise, the value of the angle on the display increases,
 - direction Left – the antenna rotates counter clockwise, the angle value on the display decreases.
- The [Up] and [Down] buttons are used to change elevation of the antenna:
 - direction Top – rotor turns to the right looking at its front. The value of the angle on the display increases,
 - direction Down – the rotor rotates to the left looking at its front. The angle value on the display decreases.

The directions of change elevation of the rotator:

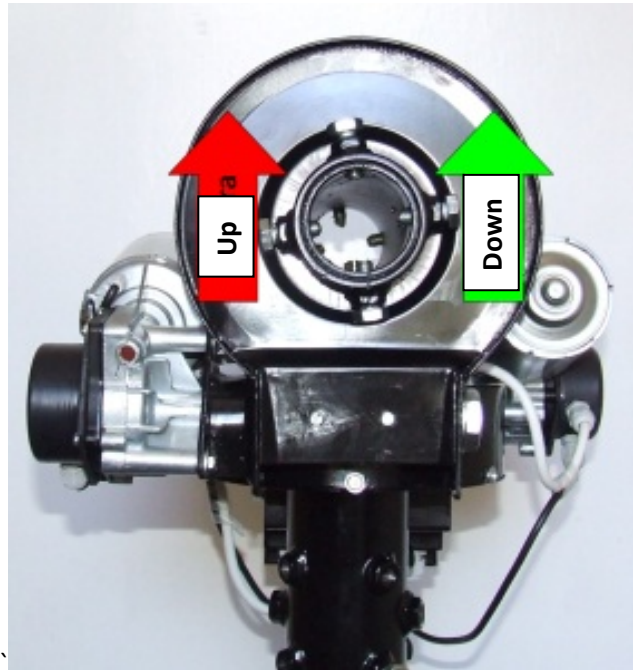

After installation the optional CCM (Current Measurement Module), the user can observe the value of the motors' current. To activate this function, press the [F2] button once. On the LCD screen, where the rotor position is indicated, the current values of the respective motors will appear. The occurrence of slight fluctuations in current indications during the rotor standstill is a normal situation and results from the internal noise of the measuring sensor. Sample LCD screen during rotor operation:

```
MODE: NORMAL
A1: 1.4A E2: -2.1A
```

MOTOR ANGLES

is a calibration mode of the actual rotator's position relative to geographical directions.

To activate calibration mode press the [F] button. In this mode, user can set any value of the azimuth and elevation angle, without rotating the antenna. We do this to adjust the displayed values to the actual position of the antenna.



Verification of the actual position of the antenna in relation to the displayed values should also be done preventively. This is to maintain the operation of the antenna and wiring within the assumed angular limits. It is suggested that during the operation of the rotor, observe its operation and the position of the antenna (directly or through the camera) and in the event of irregularities, immediately stop the rotor by switching off the controller.

To set desired azimuth angle, we use the [Left] and [Right] buttons, and change the elevation angle with the [Top] and [Down] buttons.

Resetting the azimuth angle is done by pressing the [F1] and [Left] buttons at the same time, and resetting the elevation angle – with the [F1] and [Top] buttons.

Returning to normal operation by pressing the [F] button (a few times if needed).

SPEED CALIBR.

is a calibration for SOFTLY and SATELLITE modes.



In order to properly calibrate, the procedure for setting the minimum motor power (MIN POWER) capable of moving the antenna system must be carried out beforehand. Therefore, the rotor should be mounted at the target location and the antenna system installed on the rotator. This is crucial for the proper operation of the SOFTLY function, so it should be carried out with due diligence.



Note: both the MIN POWER setting and the SOFTLY mode calibration should be carried out whenever the load on the motors may have changed significantly, e.g. a change in the antenna system, a significant change in the outside temperature (due to the higher resistance to movement of the antenna system and the gears themselves), other factors affecting the resistance to movement and the minimum torque capable of moving the antenna system. It should be taken into account that the antenna system may pose different resistance to the rotor motors depending on the selected azimuth and elevation, this may be influenced by, for example, the balance of the antenna system, the tension of antenna wires, etc.

Calibration procedure:

1. In the MOTOR CONFIGURATION menu for both motors, set START and STOP to SOFTLY. We approve and save the selection.
2. Start the configuration mode using the F button [MODE: SPEED CALIBR.], to confirm the choice, press and hold the S button for min. 10s – this will start the calibration procedure. When confirming the start of the calibration procedure, the user must be aware that the controller will automatically start the rotor motors – the antenna system and the objects within its range should be prepared in advance for safe operation. **Remember: at any time, the procedure can be interrupted by turning off the controller with the main power switch!**
3. After starting the calibration mode, the controller:
 - a. will bring the rotor to the position of 0 ° azimuth and 0 ° elevation,
 - b. for each of the motors will carry out a series of tests consisting in starting in work cycles in the range of about 0-10 ° respectively for azimuth and elevation, analysing the actual speed of the set at this time,
 - c. informs about the progress of calibration indicating the percentage of advancement on the screen,
 - d. after the calibration is completed it automatically goes to NORMAL mode.

3. Explanation of the operation of ramps on the example of the following graphs:

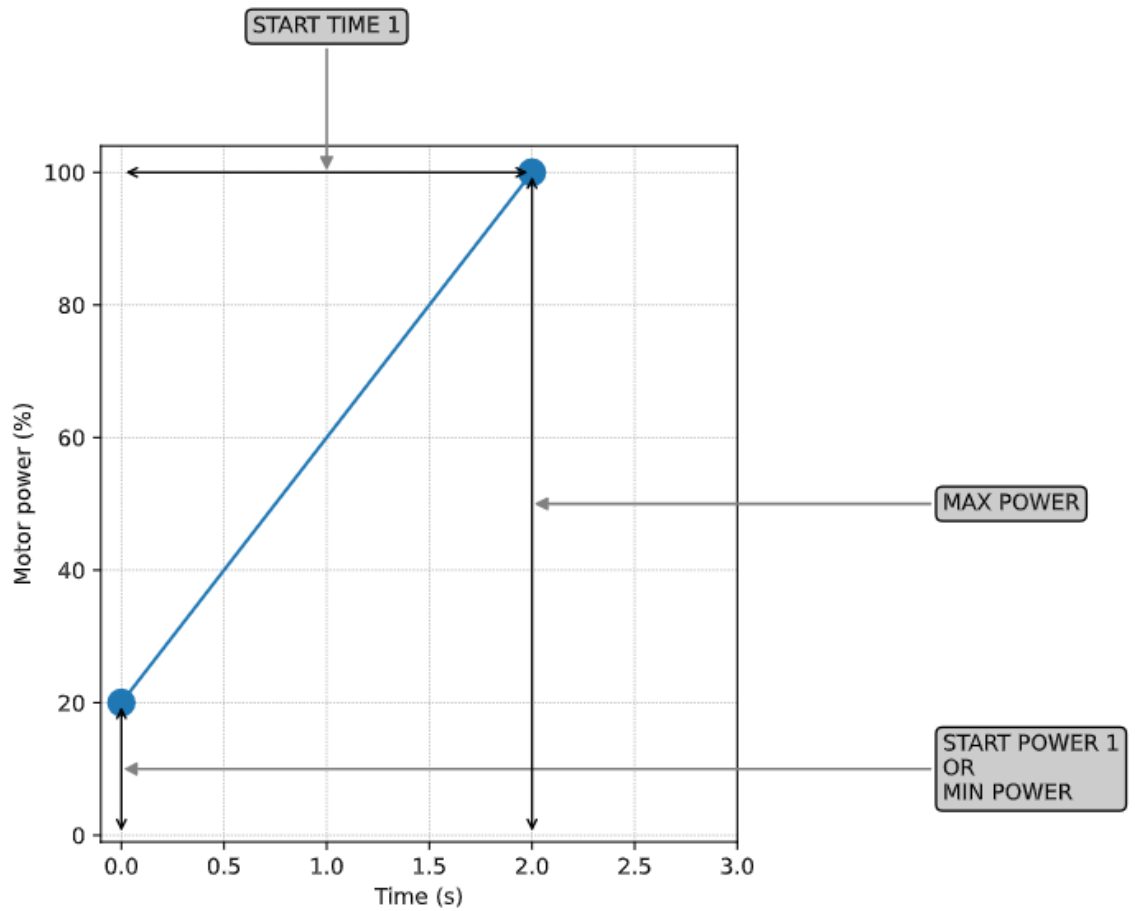

A diagram (above) of the starting ramp, where the controller will start the motors with a power of START POWER of 20% (in this case such as MIN POWER) and at the time of START TIME 1 (here 2s) will smoothly increase the power to the value of MAX POWER (in this case to 100%).

In the case of approaching the final set position, the controller will start the deceleration process, in which for 1s (selected STOP TIME) it will reduce the power of the motors to MIN POWER and stop them (this last part of the process is not visible on the graph).

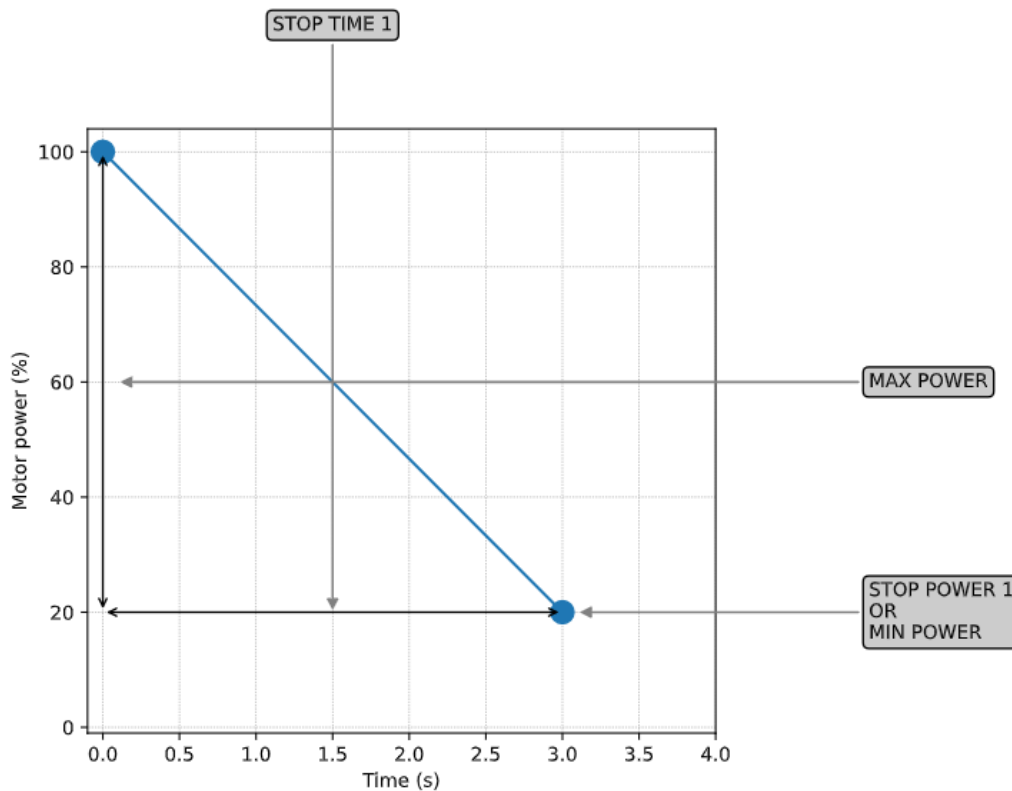

A diagram of the stop ramp, where the controller will start the stopping process from MAX POWER (in this case 100%) to STOP POWER (in this case 20%), and this process will take place during STOP TIME 1 (here 3s).



Comment: if you select the **START POWER** and/or **STOP POWER** value smaller than **MIN POWER**, the controller will use the **MIN POWER** value in these places, similarly for the **START POWER** and/or **STOP POWER** value greater than **MAX POWER**, the controller will use the **MAX POWER** value in these places, which means that the **MIN POWER** and **MAX POWER** values declared by the user are superior.



Completion of procedures:

1. minimum engine power settings (**MIN POWER**),
2. calibration of the **SOFTLY** function,
3. settings for start and stop increment ramps,

means that the configuration of the motors in the antenna-rotator-controller system has been completed.

After calibration, save the settings and return to **NORMAL** mode by pressing the [F] button (a few times if needed).

Controller configuration

Entering the configuration mode is obtained by pressing the [S] button when the controller is in **NORMAL** mode.

The configuration structure of the controller is modular. Changing modules is done by using the [Right] and [Left] buttons. In each module there are appropriate parameters. After selecting the module press the [S] button to enter into a parameters list. Moving between parameters is done in the same way as changing

modules - the [Right] and [Left] buttons, and the parameter value changes with the [Up] and [Down] buttons. Module selection is done by pressing the [S] button.

The [F] button is used to exit the configuration. After pressing, a question appears about saving any changes in the configuration. If you want to confirm the changes, press the [Left] YES button, if you want to return to the previous configuration without saving, press the [Right] NO button.

MOTOR CONFIGURATION

The number before the sign ": " in the TEMPLATE name specifies to which connector on the rear panel the motor must be connected: 1 – AZIMUTH 2 – ELEVATION

TEMPLATE

The type of motors connected to the controller is set in advance according to the following templates:

- **1:NC, 2:NC** – no motors connected to the controller,
- **1:AZ, 2:NC** – one motor is connected to the AZIMUTH plug on the rear panel of the controller.
The motor rotates only in azimuth plane,
- **1:NC, 2:EL** – one motor is connected to the ELEVATION plug on the rear panel of the controller.
The motor rotates only in the elevation plane,
- **1:AZ, 2:EL** – two motors are connected to the controller. Motor 1 (AZIMUTH plug) rotates in the azimuth plane, and Motor 2 (ELEVATION plug) – in the elevation plane,
- **1:AZ, 2:AZ** – two motors are connected to the controller, both rotates only in the azimuth plane,
- **1:EL, 2:EL** – two motors are connected to the controller, both rotates only in the elevation plane,
- **1:AX, 2:EY** – two motors are connected to the controller. Motor 1 (AZIMUTH plug) rotates in the X axis, and Motor 2 (ELEVATION plug) – in the Y axis. In the case of this template, the corresponding transformation (AZ/EL to X/Y) takes place directly on the controller,
- **1:XX, 2:YY** – two motors are connected to the controller. Motor 1 (AZIMUTH plug) rotates in the X axis, and Motor 2 (ELEVATION plug) – in the Y axis. Note: this is an advanced mode, intended only for dedicated solutions in which X and Y parameters ("raw data") are sent directly to the controller, i.e. the appropriate transformation (AZ/EL to X/Y) does not take place in the controller but in external software.

Rotator X/Y – important:

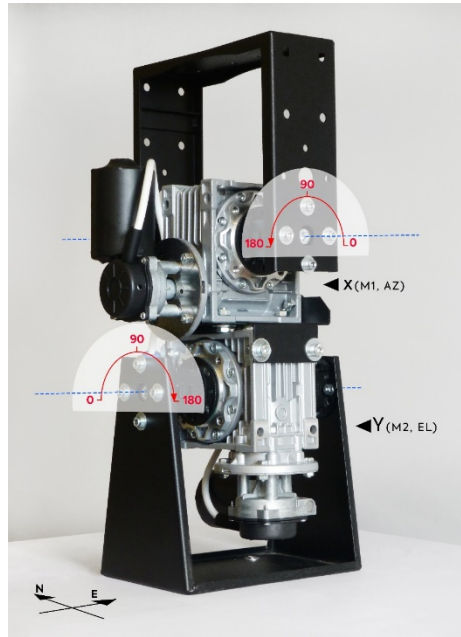

View of the SPX X/Y rotor with axis marking, motors names and operating ranges

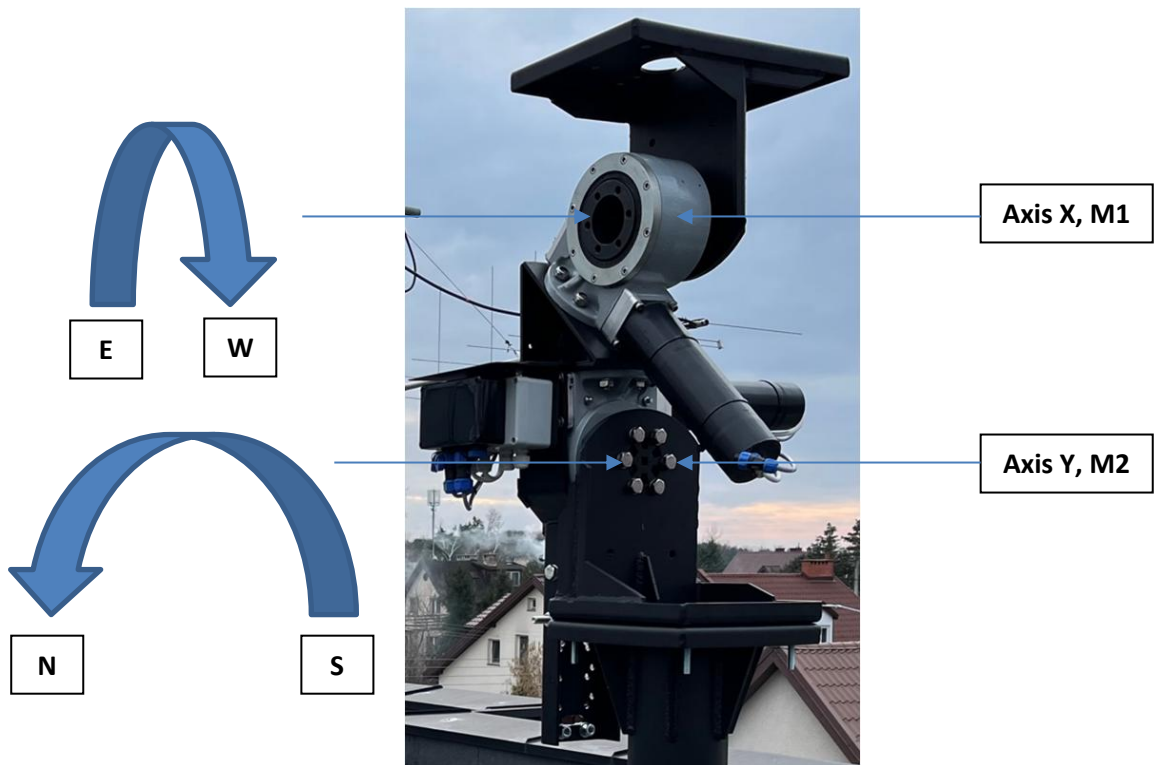

View of the SDD X/Y rotor with axis marking and motors names

- The correct positioning of the X/Y rotor should be done with setting the "zero" initial position of the rotor on the mast: the positions of the X and Y gears should be set in the middle of the operating range (90 deg.), which should lead to the position of the mounting plane of the antenna mounting plate horizontally in both planes (as shown above).
- At a "zero" position, the X and Y axes should be oriented as follows:
 - X-axis -> North-South,
 - Y-axis -> East-West.
- Edge values of the X and Y gear positions and the corresponding actual position of the rotator:
 - $X(0^\circ) = 90^\circ \text{ AZ}$
 - $X(180^\circ) = 270^\circ \text{ AZ}$
 - $Y(0^\circ) = 0^\circ \text{ AZ}$
 - $Y(180^\circ) = 180^\circ \text{ AZ}$
- To set the mounting position of the rotor operating in 1:AX, 2:EY template and to calibrate the indication, switch to 1:XX, 2:YY template.
- Do not forget to go back to the 1:AX, 2:EY template when setup is done or stay in 1:XX, 2:YY template just when going to send raw X-Y data to the controller (Non-standard setup, only for specific application!).

The first tests of the rotator's operation after connecting and configuring the controller should be carried out under constant observation of the rotator's movements, and in the event of any irregularities, immediately turn off the power supply. Caution is required due to the large forces on the rotor gears and the potential user error in connection and / or configuration of the controller. The identified irregularities should be removed before the next start-up.

Start

Motors starting modes:

- **IMMEDIATELY** – the motor starts at the maximum speed, set for each motor separately accordingly in the modules **SET MOTOR 1** and **SET MOTOR 2**,
- **SOFTLY** – the so-called "soft start" set for each motor in **SET MOTOR 1** and **SET MOTOR 2**.

Stop

Motors stopping mode:

- **IMMEDIATELY** – the motor stops immediately,
- **SOFTLY** – the so-called "soft stop" set for each motor in **SET MOTOR 1** and **SET MOTOR 2**.

Start and Stop – important information:

- In manual mode always (i.e. regardless of the selected IMMEDIATELY or SOFTLY mode) at start-up the following engine power ramp applies: by 1s MIN SPEED and then MAX SPEED, while the STOP command is executed immediately.
- In the SOFTLY manual operation mode, the ramps declared in the settings always apply at start and stop, but if the direction button was released at a speed lower than MIN SPEED, the system goes into braking in accordance with the ramp and returns to the position from the moment of releasing the direction button (thanks to this, vibration of the antenna system are avoided during manual operation and this makes it easier to select the expected position).

Satellite Mode

- **ON** - turning on,
- Properties:
 - optimized to track satellites in LEO orbit,
 - increases smooth operation and reduces the load on motors, gears and relays (note: at the expense of a slight reduction in accuracy),
 - works only with sensors type HR and CAN Bus.
- Description of the algorithm: in Satellite Mode, the system is prepared to accept subsequent positions from the satellite tracking program much more often and switching the controller relays after the end of each rotor movement practically does not occur, unless subsequent positions change the direction of movement of one of the motors and the configuration of the motors has been made correctly.

Note: with improperly set parameters of ramps and engine power, the frequent exceeding of the set position may occur (e.g. due to system inertia), which will cause the controller to react and correct the position when receiving the next command from the tracking program (the user will observe frequent operation of relays and correction of position during satellite tracking). This is an indicator that the motors (MIN POWER, SOFTLY configuration and ramps) should be performed again. However, it should be taken into account that the correction of the position and thus the operation of relays may also occur with properly configured motors – however, it will occur relatively rarely.

External control (CONTROL xx)

This parameter determines which communication port of the controller is used to control the connected motors. Appears only when a template other than **1:NC, 2:NC**. When last template **1:AZ, 2:AZ** is selected, a different control port for each motor can be set.

Depending on the selected template, the following subtitles will appear on the screen:



- **CONTROL A1** – template **1:AZ, 2:NC**,
- **CONTROL E2** – template **1:NC, 2:EL**,
- **CONTROL AE** – template **1:AZ, 1:EL**,
- **CONTROL A2** – template **1:AZ, 2:AZ**.

CONTROL value:

- **NONE** – no external control, just manual keyboard position change.
- **COM 0** – external control according to the selected protocol, described below. You can also control manually.
- **COM 1** – external control according to the selected protocol, described below. You can also control manually.
- **USB** – control via USB D port, according to the selected protocol, described below. You can also control manually.
- **ETH** – control via ETHERNET according to the selected protocol, described below. You can also control manually.

Protocol (PROT. xx)

Choosing communication protocol between the controller and the control device (e.g. a computer with the appropriate program):

- **SPID ROT1**
- **SPID ROT2**
- **YAESU**

Motors setting (SET MOTOR 1, SET MOTOR 2)

STATE

Read-only parameter. It depends on the choice of template (TEMPLATE) in the configuration of motors. Specifies whether the motor is ON or OFF.

TYPE

Type of controller input:

- **DIGITAL** – the controller counts pulses (no other options available).

KIND

Read-only parameter. Depends on the choice of TEMPLATE in the MOTOR CONFIGURATION:

- **AZIMUTH** – rotator rotates in azimuth plane,
- **ELEVATION** – rotator rotates in elevation plane,
- **X** – rotator rotates in X axis,

- **Y** – rotator rotates in Y axis.

INPUT

Kind of input sensor (only when **DIGITAL** is chosen):

- **ELECTRONIC** – electronic motion sensors (vibration-free),
- **MECHANICAL** – reed switches,
- **CAN BUS** – for sensors such as absolute encoder and/or inclinometer, communicating with the controller via CAN BUS. Note: Requires installation of the extension card and configuration.

CAN BUS sensors configuration:

1. The operation of assigning CAN BUS sensors to the controller is best done in workshop or laboratory conditions, i.e. with convenient access to both the controller and the rotor, because for its correct performance, simultaneous access to the junction box at the rotor (access to micro-switches on the PCB) must be ensured.
2. In the configuration menu of motors (SET MOTOR) choose to which motors CAN BUS encoders are connected, selecting SET MOTOR INPUT to CAN BUS.



3. Then turn off the power of the controller and connect ONLY ONE selected to configure the encoder, by properly setting the micro-switches in the rotor junction box:

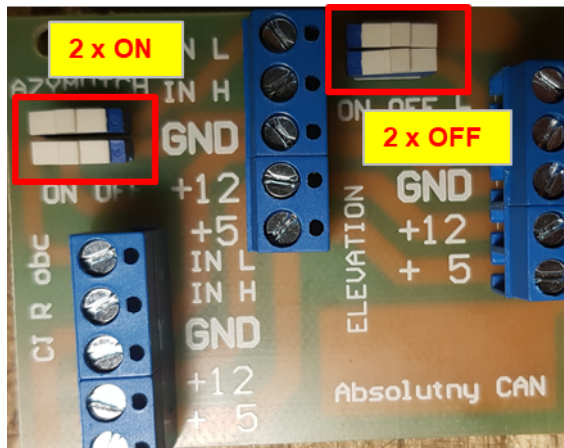

4. In the next move (with the controller constantly turned off), when holding the F2 key, turn on the power of the controller and the device starts in Setup CAN M1 mode.



5. With the <> keys select whether the connected encoder supports MOTOR 1 [AZ] or MOTOR 2 [EL].
6. We confirm the selection by short pressing the S key.
7. The device enters the mode of searching for the connected encoder and pairing it with the controller.



Setup CAN M1
Searching. (30s max)

8. If the encoder is detected and paired correctly, the following message is displayed:



Encoder found!
Please restart power

9. If it is not detected, the following message will be displayed:



Encoder not found!
Check connections!

10. If you are connecting another encoder, REMEMBER TO DISCONNECT THE CURRENTLY CONFIGURED ENCODER BEFORE CONNECTING ANOTHER ENCODER TO BE CONFIGURED, by properly setting the micro-switches in the rotor junction box:

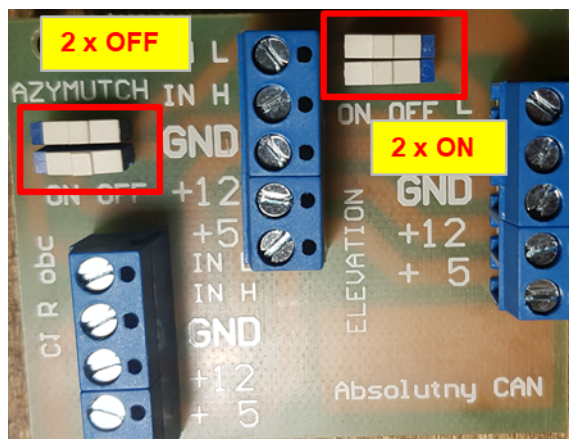

11. After disconnecting the currently configured encoder, start the procedure again with the second one as points 4-8 above. Remember to select the second motor in the menu, e.g. MOTOR 2 [EL].
12. After successful configuration of the second encoder, turn off the controller, set the micro-switches in the rotor junction box [both pairs ON]:

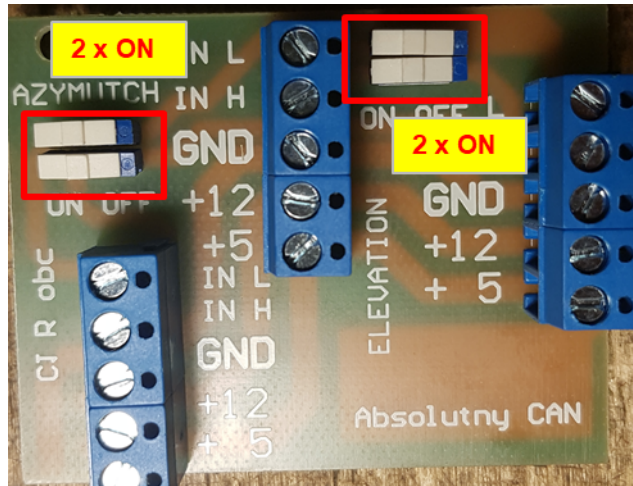

, connect both encoders and turn on

the power.

- The device is ready to work. For absolute encoders, it may require position calibration (MOTOR ANGLES).

GEAR

Gear ratio of the rotator driveshaft.

It should be noted that from firmware v2.0 the designation of the rotor gear has changed. During the process of replacing the software with a newer one, the controller itself converts the old values into the correct, new ones and usually no user intervention is required in this regard, however, the gear ratios are key parameters and their correctness should be verified by the user. The following table indicates the appropriate gear ratio values depending on the rotor type and software version:

ROTATOR MODEL	GEAR NOTATION firmware older than v.2.0	GEAR NOTATION firmware v2.0 or newer	INPUT
BIG RAS HR	0.093750	0.023438	ELECTRONIC
RAS HR	0.125000	0.031250	ELECTRONIC
RAU HR	0.187500	0.046875	ELECTRONIC
SPX 01/02/03 HR	0.140625	0.035156	ELECTRONIC
SPX SDD	-	0.013560 or 0.015500	ELECTRONIC
non HR	0.5 or 1.0	0.5 or 1.0	MECHANICAL

If the user uses other gear, can enter its ratio in the CUSTOM position.



MIN ANGLE

The minimum angle to which the rotor can be rotated (counter clockwise). Default 0 degrees for azimuth plane and 0 degrees for elevation plane.

```
SET MOTOR 1
MIN ANGLE: 0.0
```

MAX ANGLE

The maximum angle to which the rotor can rotate (clockwise). Default 359 degrees for azimuth plane and 90 degrees for elevation plane.

```
SET MOTOR 1
MAX ANGLE: 0.0
```

MAX POWER

Maximum power in percentage of the full power that the controller supply to the rotor. Default 100%.

```
SET MOTOR 1
MAX POWER: 100%
```

PULS TIMEOUT

Specifies the time after turning off the motor, if there are no pulses from the motion sensor. Applies only to rotors with DIGITAL sensors.

Setting RS232 port (SET COM0, SET COM1)

STATE

The parameter is read-only. Values **ON** – on, **OFF** – off.

BAUD

Baudrate: **600, 1200, 2400, 4800, 9600, 19200, 38400, 57600, 115200, 230400 and 460800.**

DATA BITS

Values: **4, 5, 6, 7 or 8** bits.

STOP BITS

Values: **1 or 2** stop bit(s).

PARITY

Values: **NONE, ODD, EVEN.**

Setting RS232 virtual port (SET USB COM)

STATE

The parameter is read-only. Values **ON** – on, **OFF** – off.

BAUD

Baudrate: **600, 1200, 2400, 4800, 9600, 19200, 38400, 57600, 115200, 230400 and 460800.**

DATA BITS

8 bits.

STOP BITS

1 bit.

PARITY

NONE.

Setting ETHERNET port (SET ETHERNET)

The Ethernet port is set to obtain a dynamic IP address. Communication with this port is done using one of the protocols (SPID ROT1, SPID ROT2, and YAESU). For example, the controller obtained an IP address from the DHCP server 192.168.0.10. You can connect to it, for example, from Hyper Terminal by selecting the type of TCP / IP (Winsock) connection, in the host address item enter 192.168.0.10 and the port number 23.

STATE

The parameter is read-only. Values **ON** – on, **OFF** – off.

Dimensions:

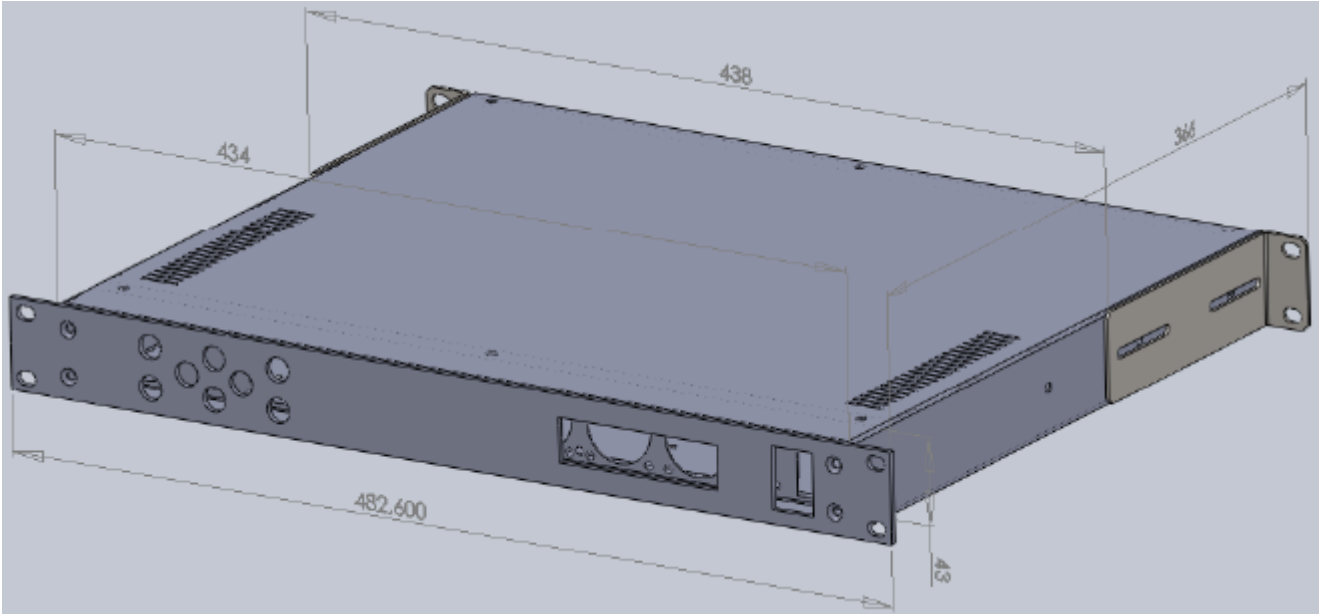

MD-01 FRONT

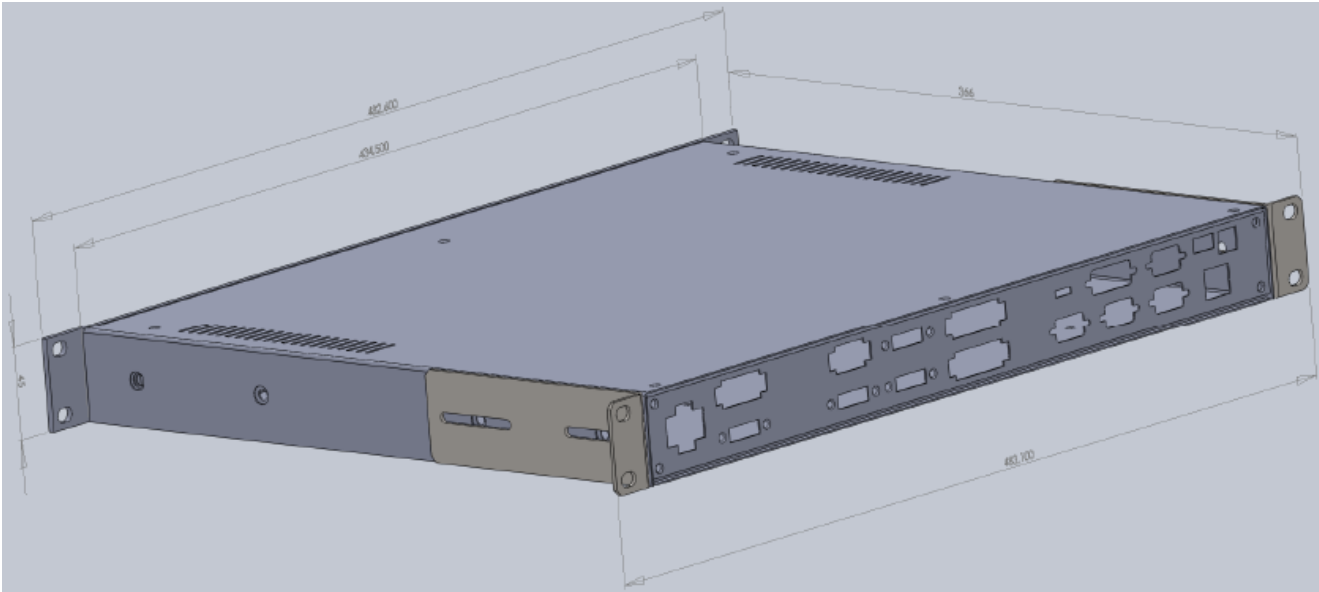

MD-01 BACK

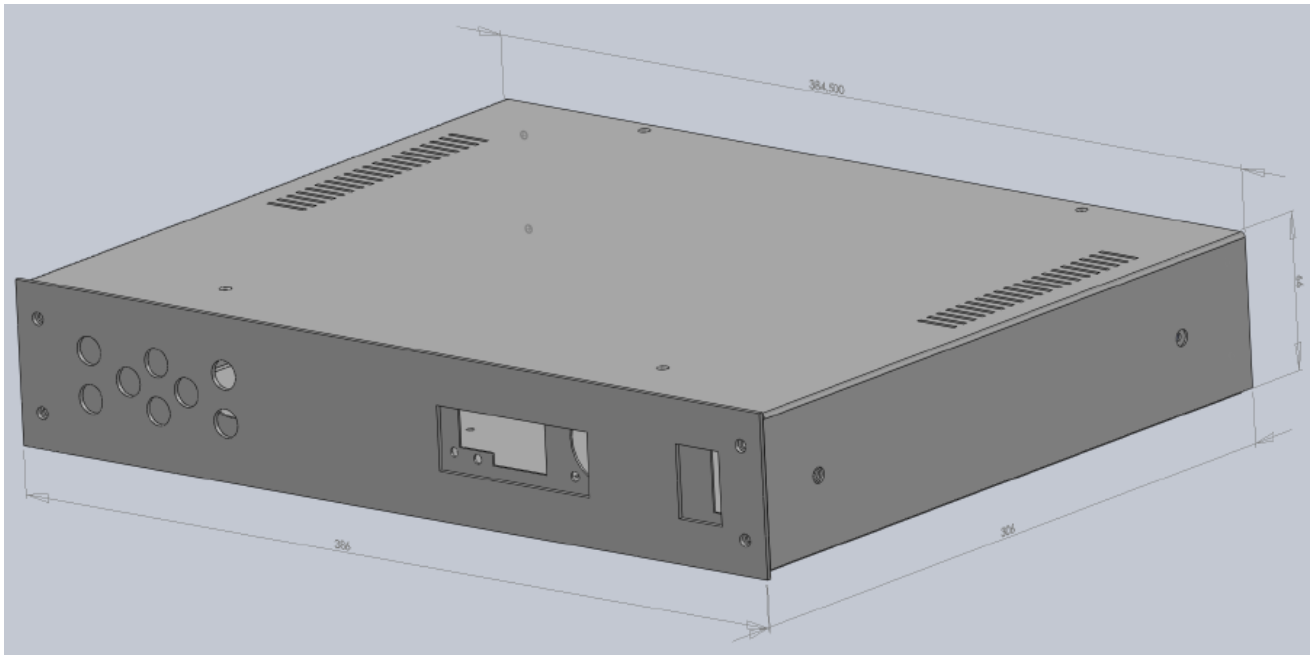

MD-02 FRONT

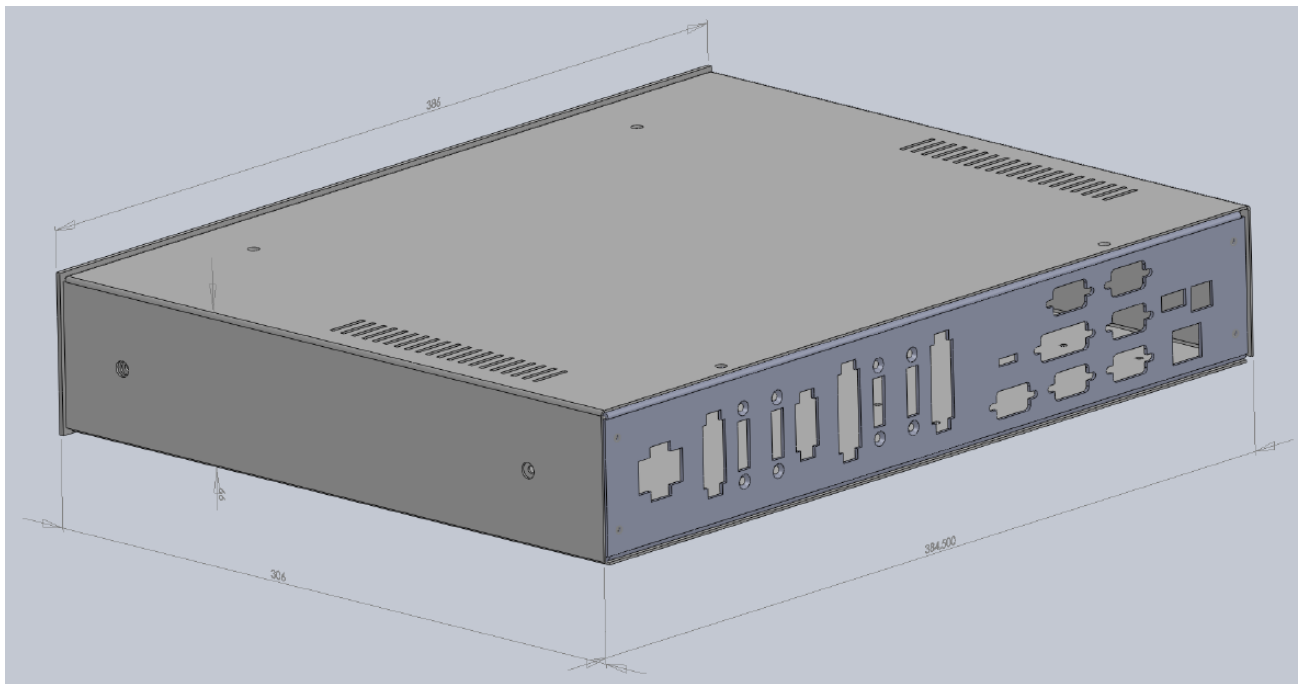

MD-02 BACK

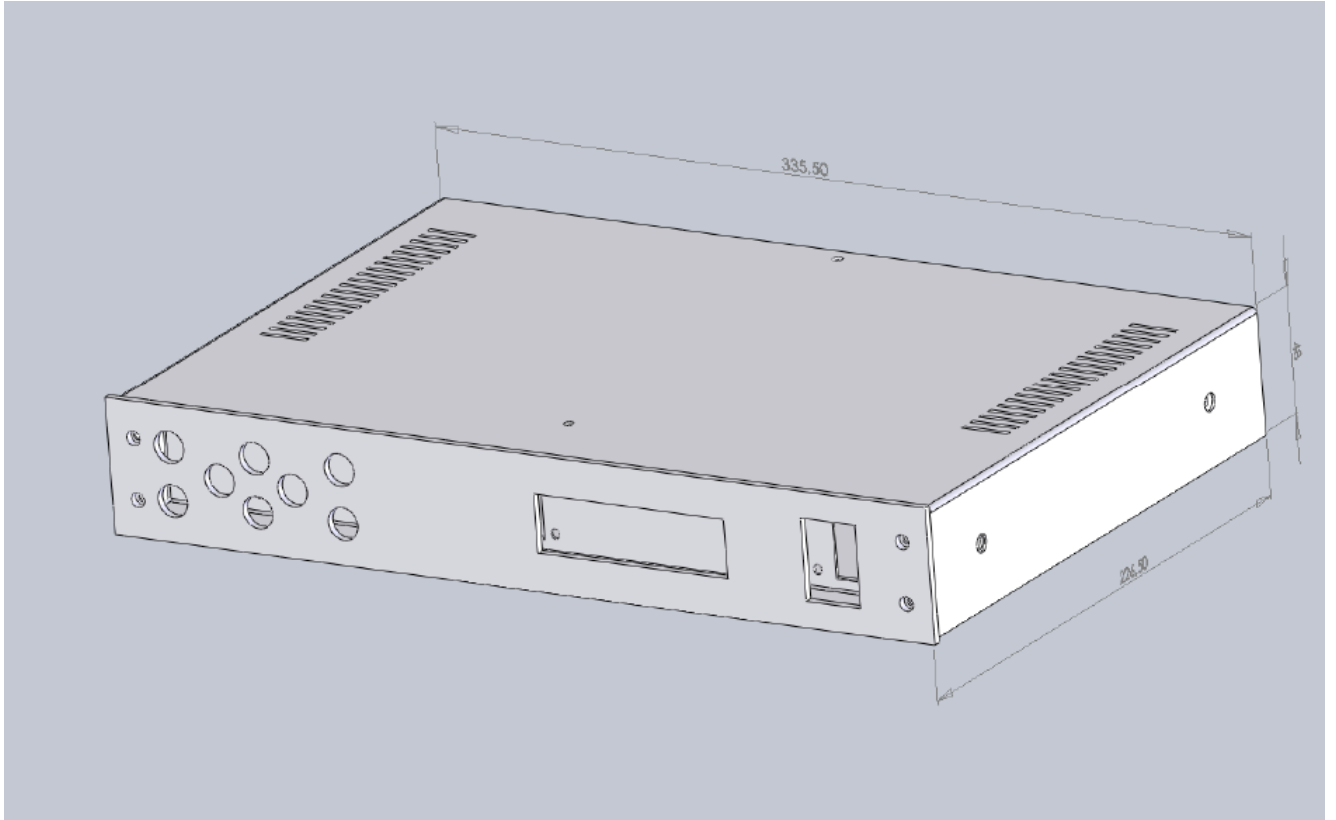

MD-03 FRONT

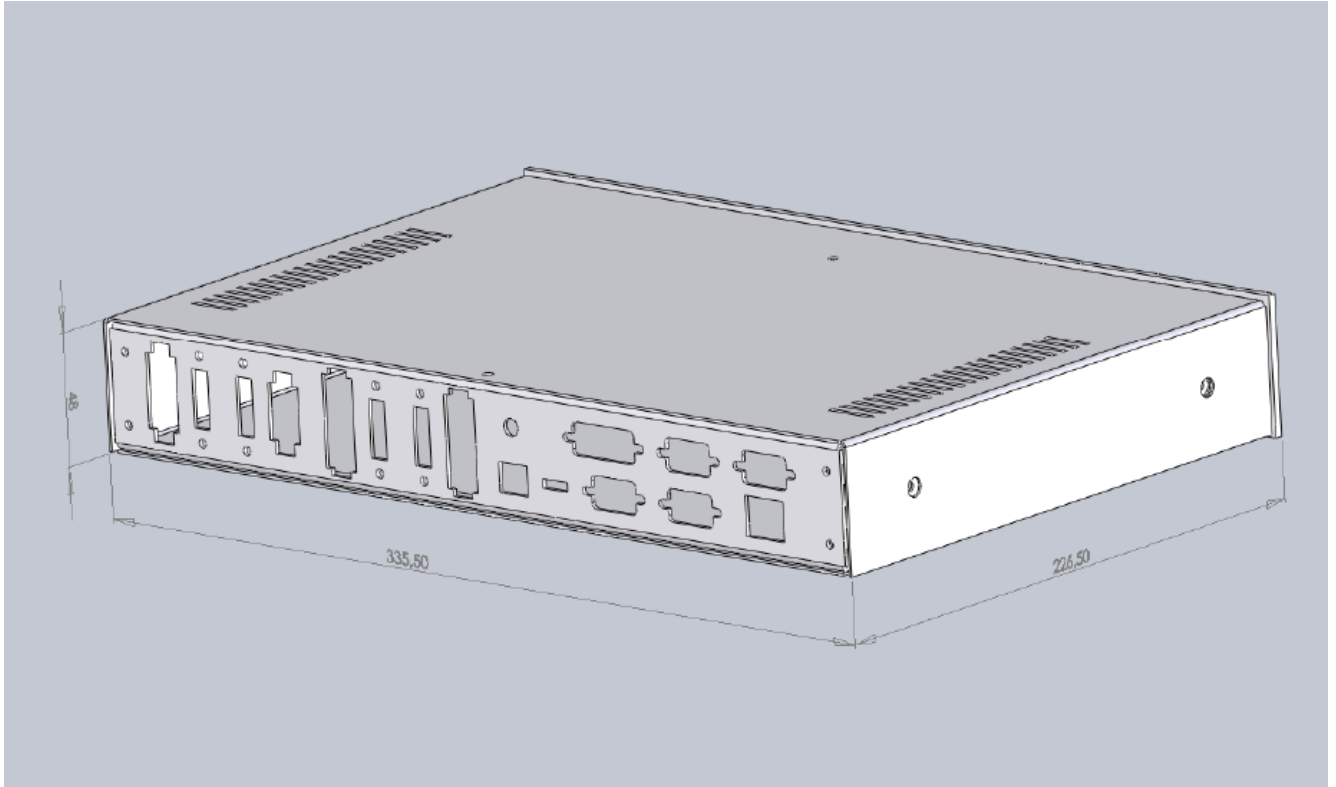

MD-03 BACK

ACCESSORY

IMP/HR sensors module:

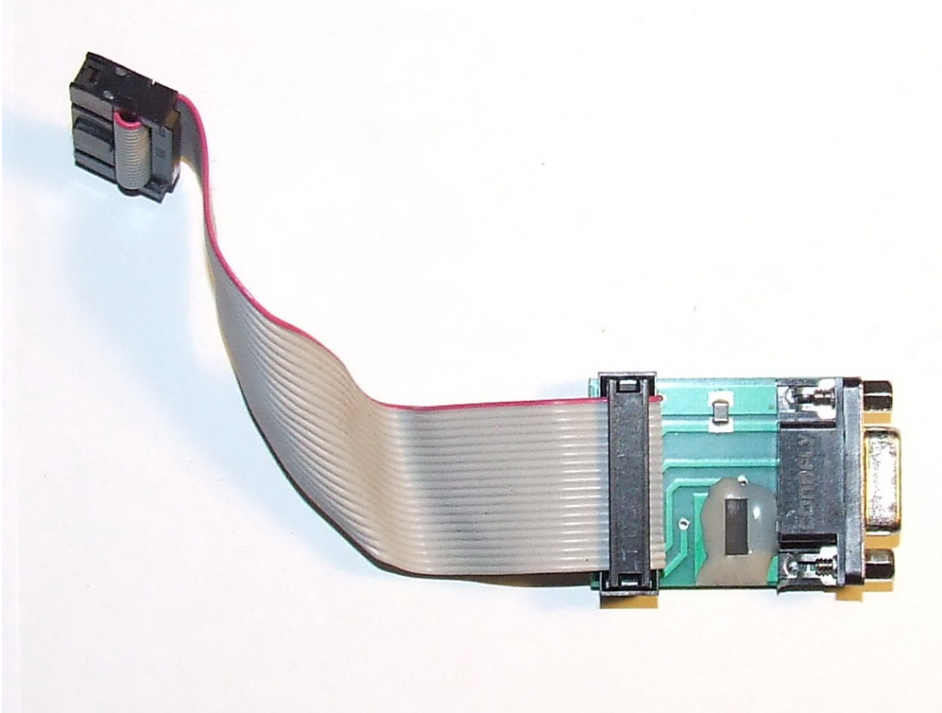

CAN BUS sensors module:

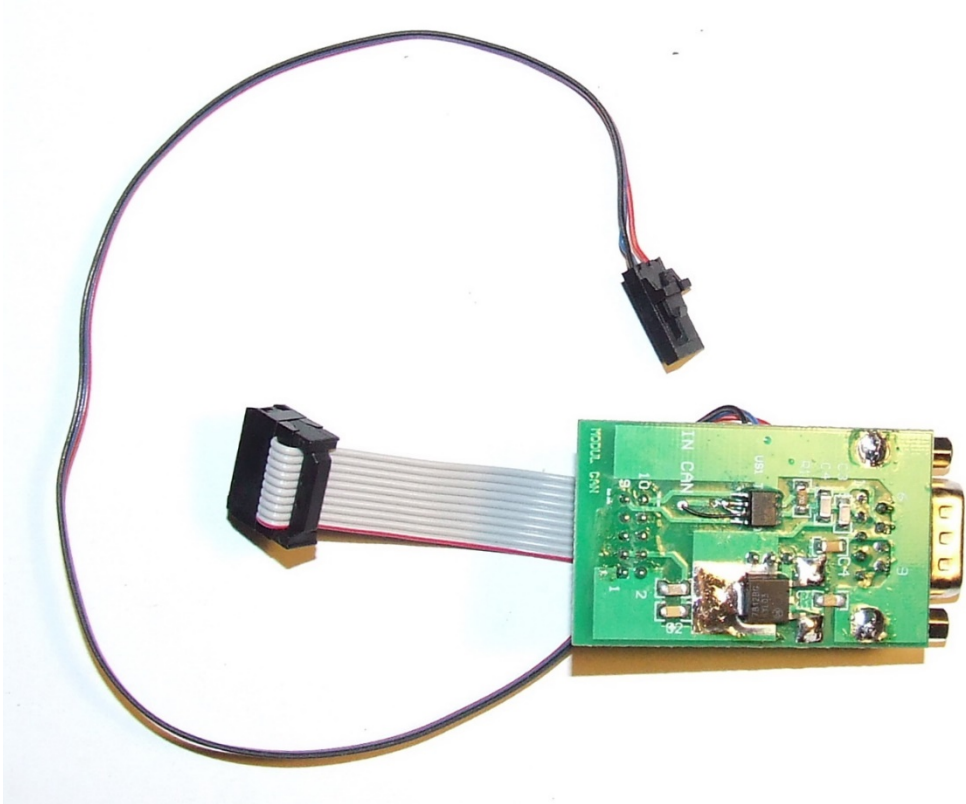

COM1 cable for MD-03:



CABLE CONNECTIONS

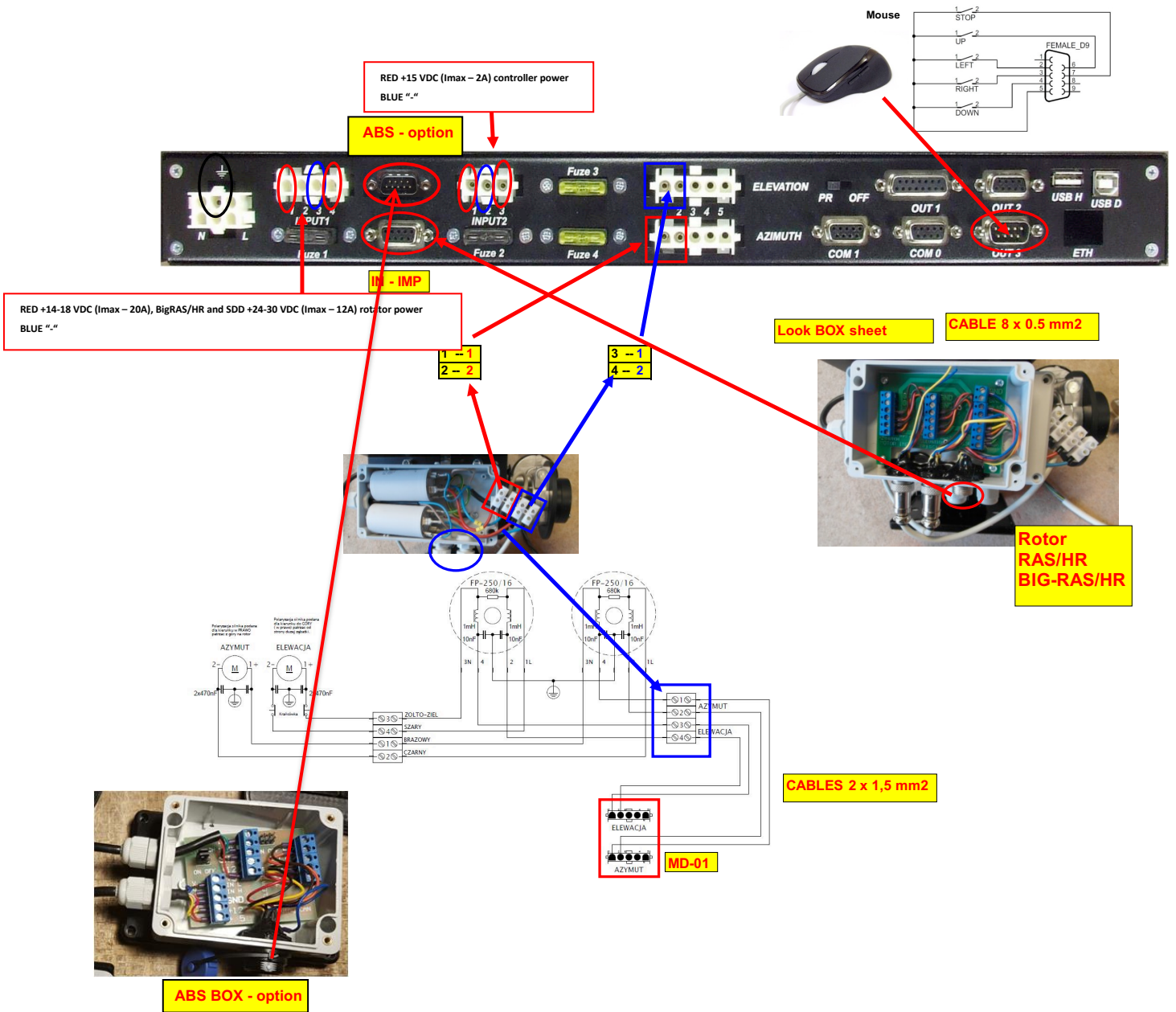

MD-01 controller to RAS/HR or BIG RAS/HR or BIG RAS/HR ABS connection diagram

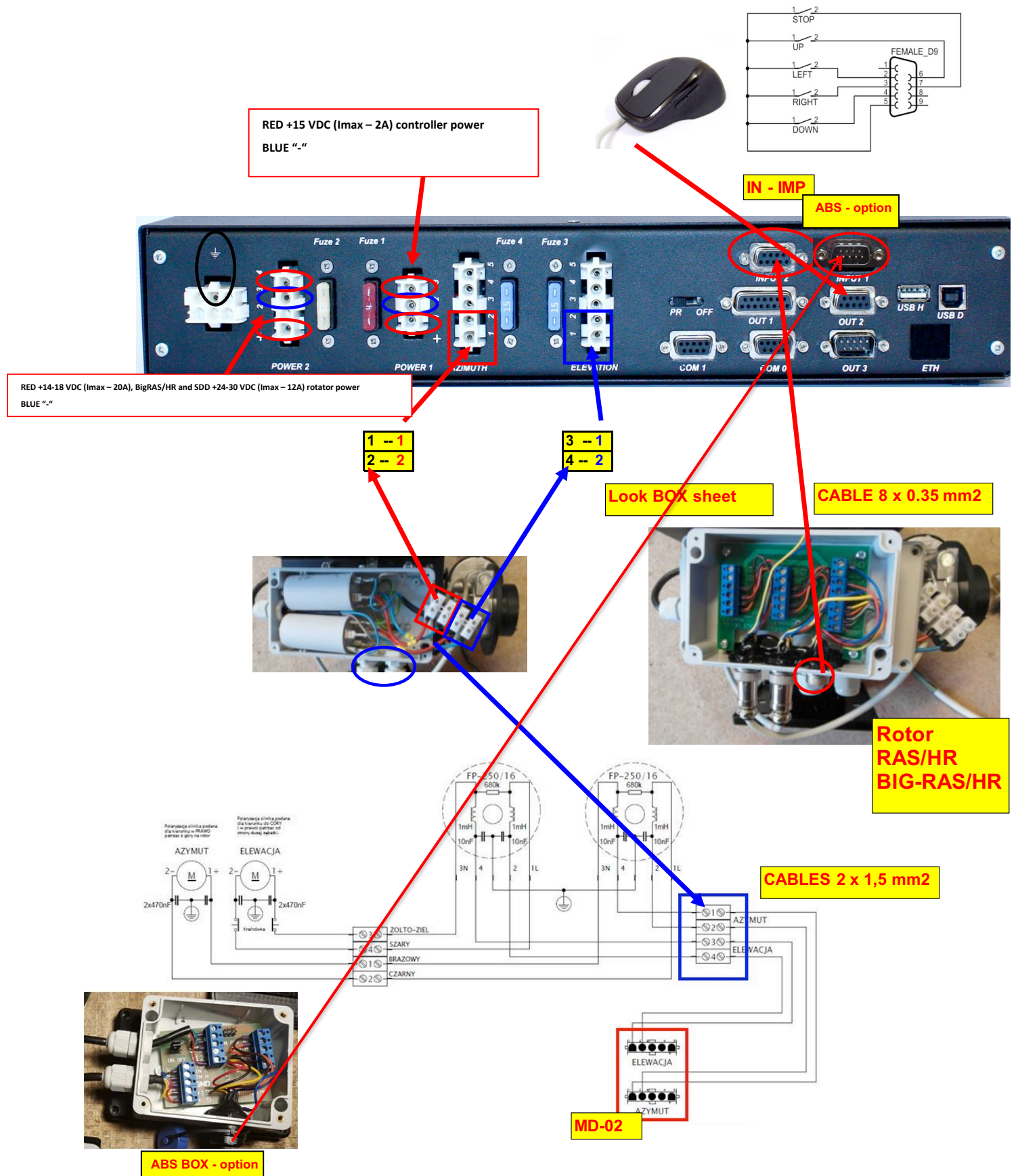

RED +15 VDC (Imax – 2A) controller power
BLUE “-“

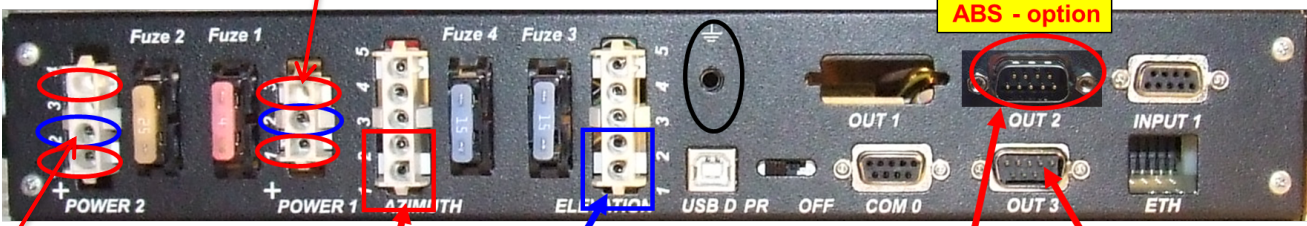

RED +14-18 VDC (Imax – 20A), BigRAS/HR and SDD +24-30 VDC (Imax – 12A) rotator power
BLUE “-“

1->1
2->2

3->1
4->2

CABLE 6 x 0.22 - 0.5 mm2

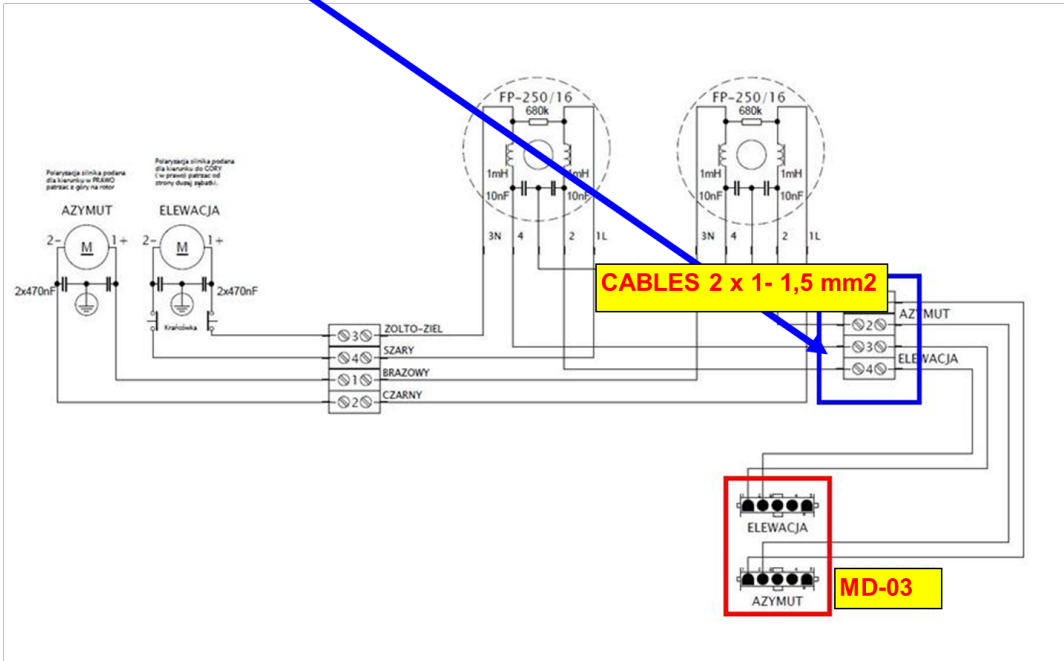
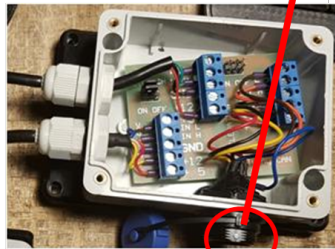
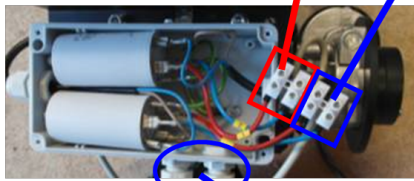
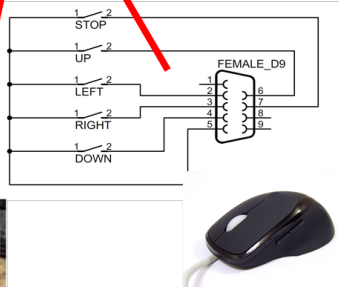

MD-03 controller to RAS/HR or BIG RAS/HR or BIG RAS/HR ABS connection diagram



MIC338

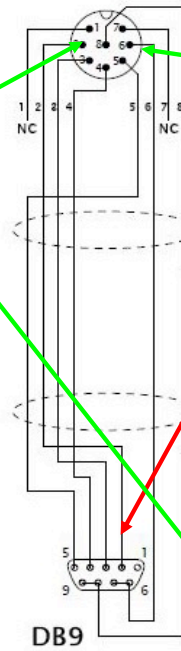

DB9

MIC338

NC	1	1	BLUE
IMP2 EL	2	2	YELLOW
IMP1 EL	3	3	BROWN
IMP1 AZ	4	4	BLACK
IMP2 AZ	5	5	RED
PLUS +	6	6	ORANGE
PLUS +	7	7	GREY
MINUS -	8	8	GREEN
MINUS -	9	9	

Distance 100 - 150 m

PIN	what	3 cable
1	NC	
2	IMP2 EL	cable 1 + Ground
3	IMP1 EL	
4	IMP1 AZ	cable 2 + Ground
5	IMP2 AZ	
6	PLUS (+)	cable 3 + Ground
7	NC	
8	MINUS (-)	
9	NC	

OR

Distance 0 -100 m

PIN	what	1 cable
1	NC	
2	IMP2 EL	cable 1 + Ground
3	IMP1 EL	
4	IMP1 AZ	
5	IMP2 AZ	
6	PLUS (+)	
7	NC	
8	MINUS (-)	
9	NC	

WEIPU Connector Sp17 Series IP68



Mail contact
face view connector
Junction box rotor

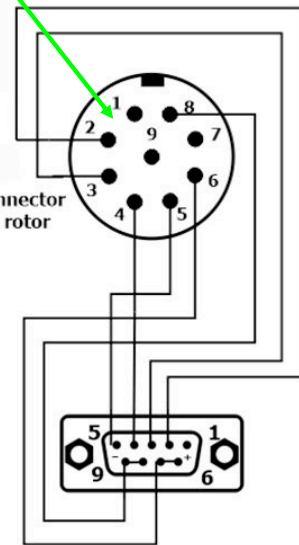

DC
NC

Db9 Mail connector view pin
connection side MD-0X
controller.

Connection between A/Z HR or X/Y HR rotator and controller

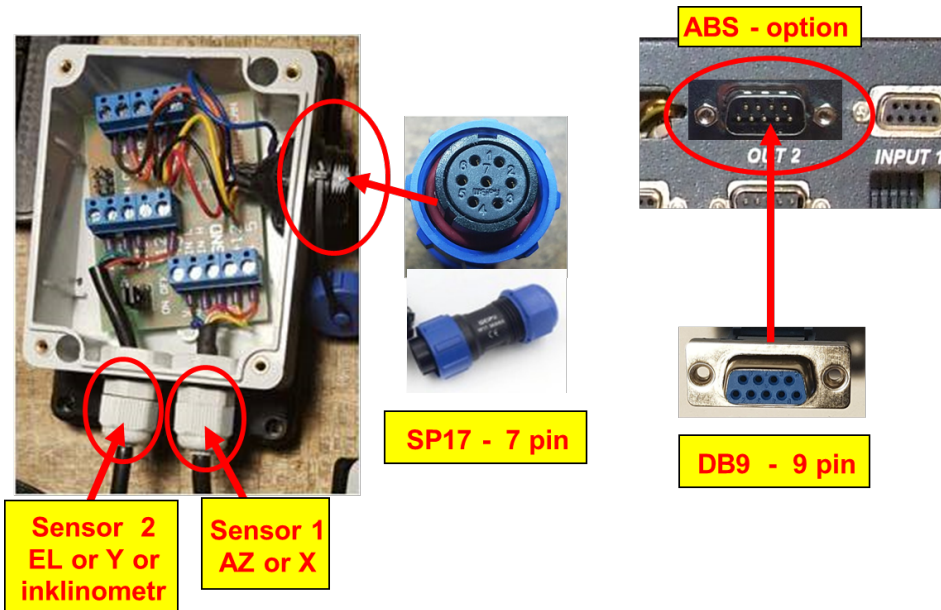

PIN SP17	PIN DB9
5	1
3	2
4	3
NC	NC
NC	NC
NC	NC
6	7
NC	NC
2	9



Connection between MD-0x controller and rotator with optional ABS sensors

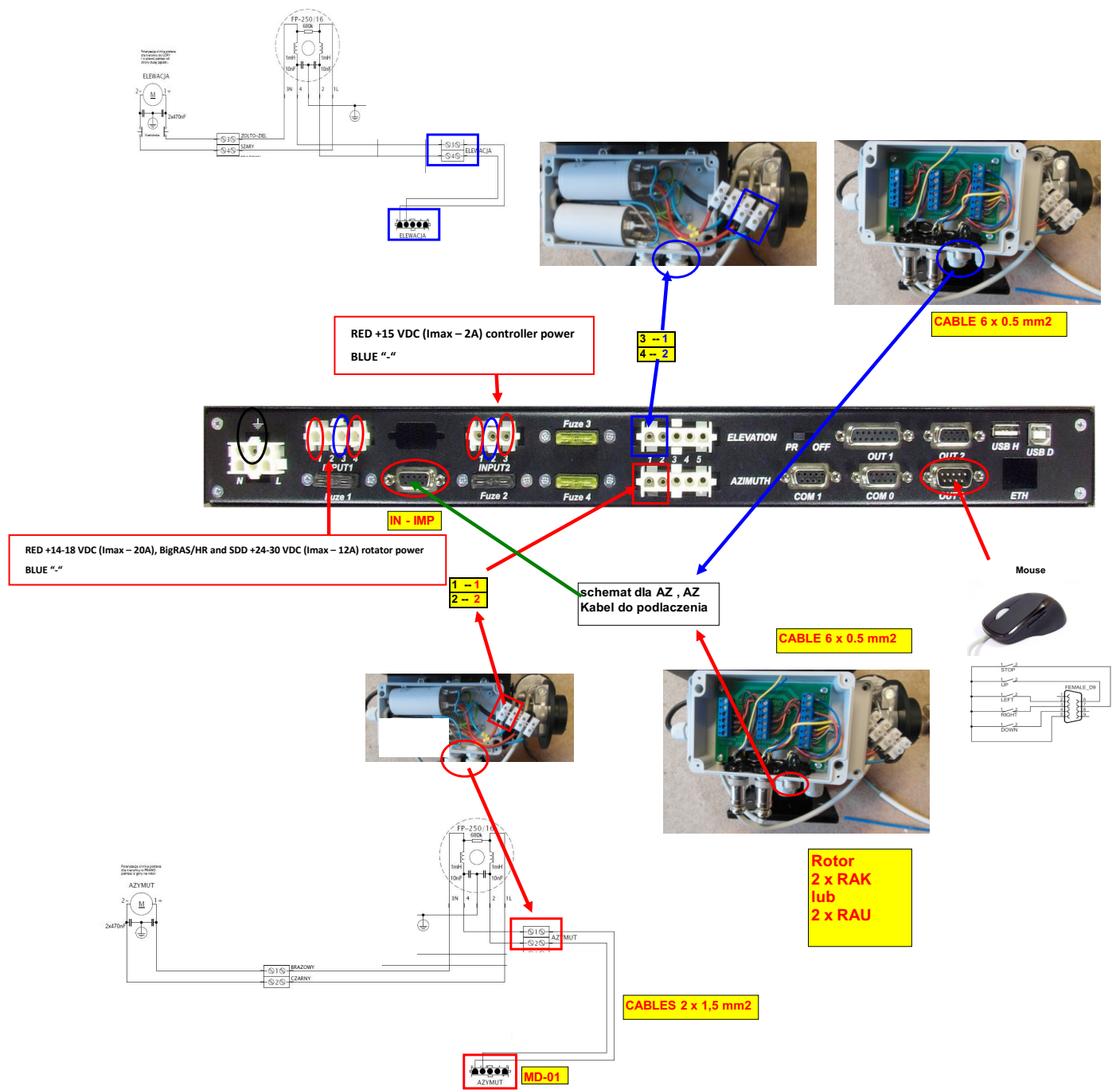

Connection between RAK/HR or RAU/HR rotator and MD-01 controller

Sensors connection at rotator HR type

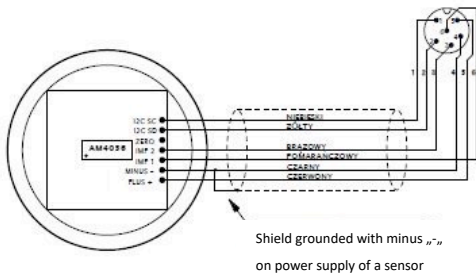

Sensors connection at MD-01 controller

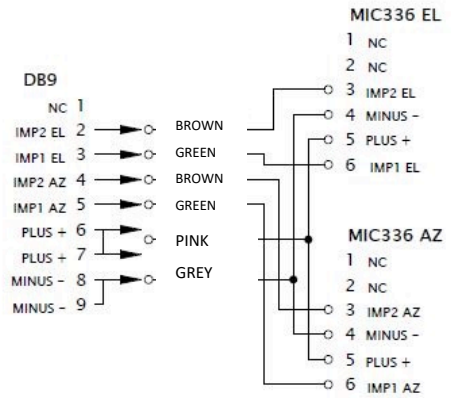

PCB AM4096		MIC336	
I2C SC	1	1	BLUE
I2C SD	2	2	YELLOW
ZERO	3		
IMP 2	4	3	BROWN
IMP 1	5	6	ORANGE
MINUS -	6	4	BLACK
PLUS +	7	5	RED

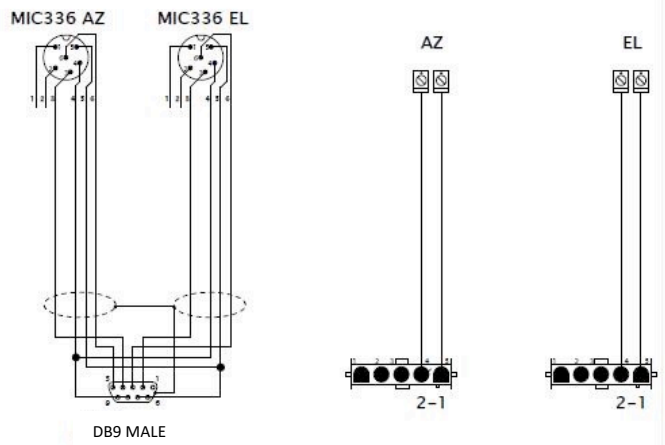

Distance 0 -100 m

PIN	what	3 cable
1	NC	
2	IMP2 EL	cable 1 + Ground
3	IMP1 EL	
4	IMP1 AZ	cable 2 + Ground
5	IMP2 AZ	
6	PLUS (+)	cable 3 + Ground
7	NC	
8	MINUS (-)	
9	NC	

OR

Distance 0 -100 m

PIN	what	1 cable
1	NC	
2	IMP2 EL	cable 1 + Ground
3	IMP1 EL	
4	IMP1 AZ	
5	IMP2 AZ	
6	PLUS (+)	
7	NC	
8	MINUS (-)	
9	NC	

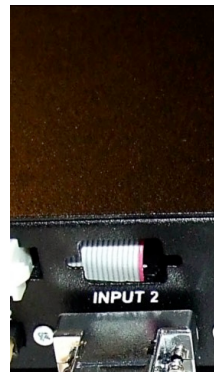

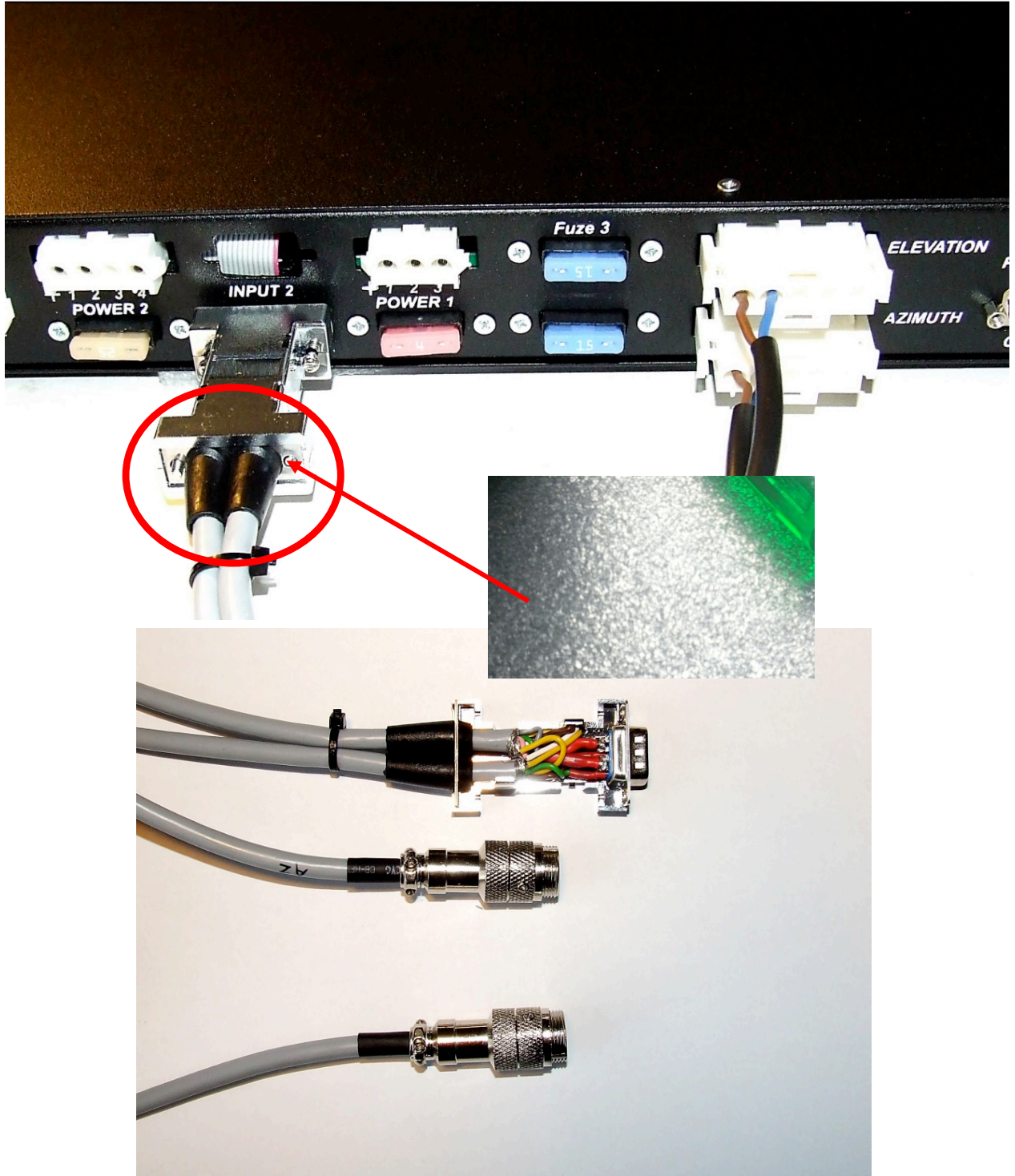

Connection between SPX HR rotator and a controller

ETHERNET MODULE v1

User installation

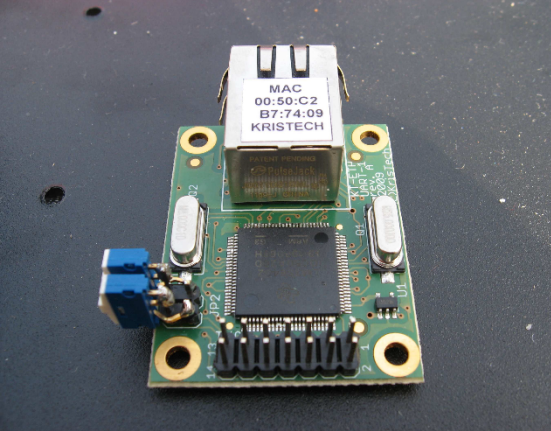

Unscrew the screws that fix the top cover of the controller. Open the controller by removing the cover and find the empty space on the left when the display is turned facing the user. Place the Ethernet module on the connector and secure it with screws. MAC ADDRESS is located on the Ethernet connector sticker – save it for connection. Reattach the top cover - the device is ready for use.

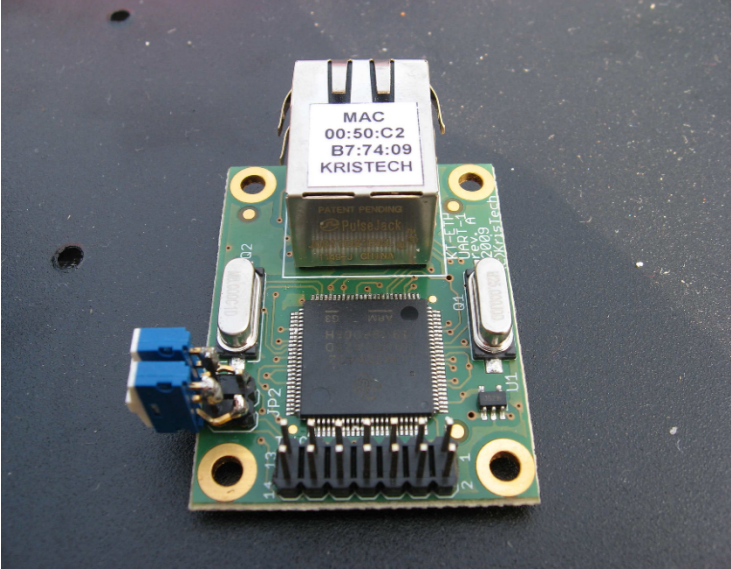

Configuration

The operation mode of the module is configured by micro-switches:

PIN1 OFF	web server is active
PIN1 ON	web server is offline
PIN2 OFF	mode according to user's network configuration
PIN2 ON	DHCP mode

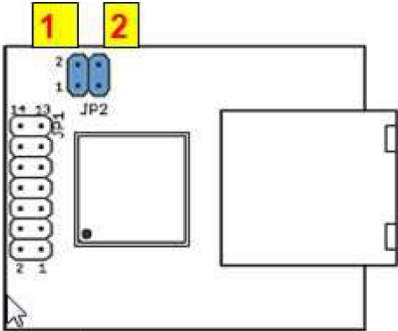
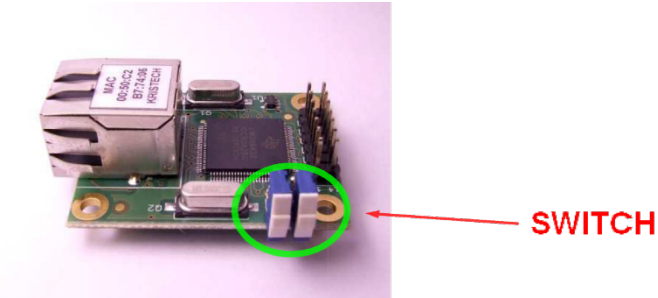
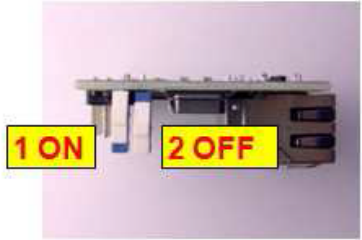
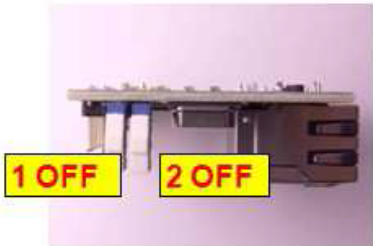

ETHERNET MODULE v2

User installation

The complete Ethernet module set includes: main unit, mount board and connection cable.

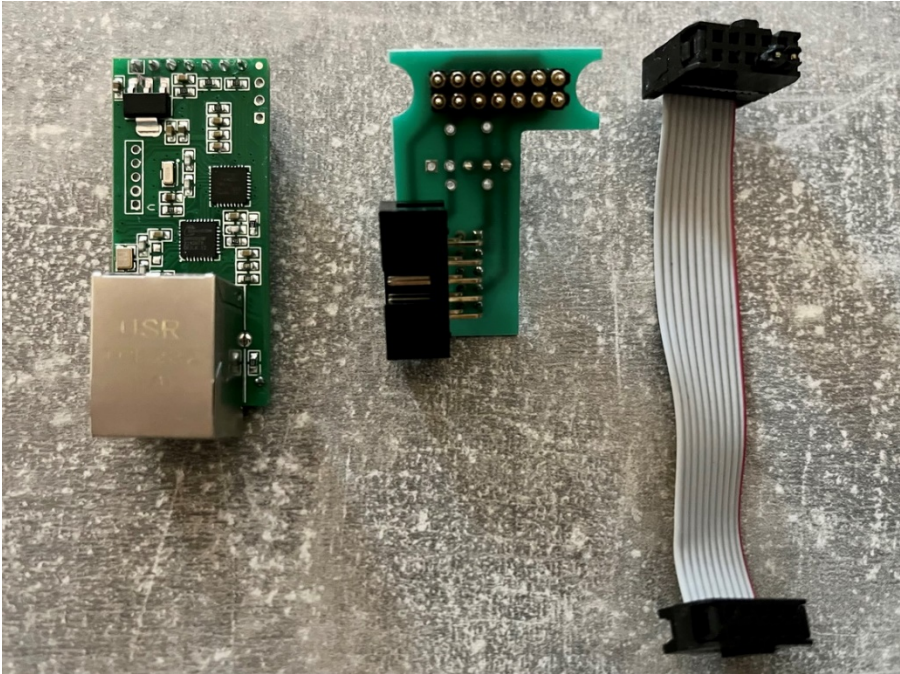

Ethernet module set (from left to right): main unit, mount board, connection cable

Unscrew the screws that fix the top cover of the controller. Open the controller by removing the cover and find the empty space on the left when the display is turned facing the user. Follow hardware installation below:

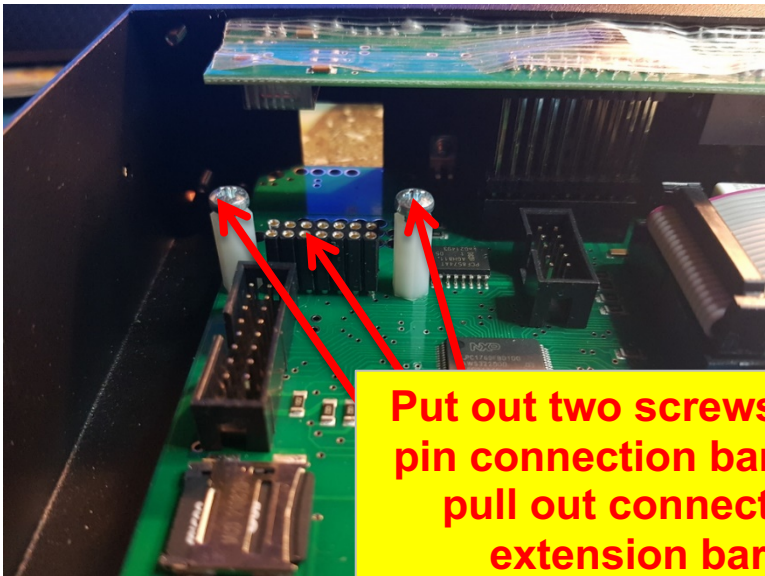

**Main board connector
ready for mount board
installation**

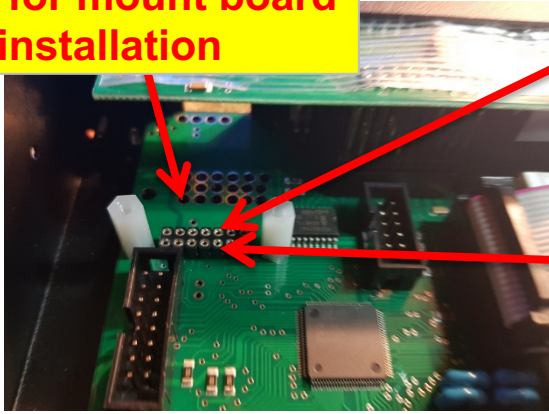

**Put 2x7 pin connector of
mount board to the main
board connector**

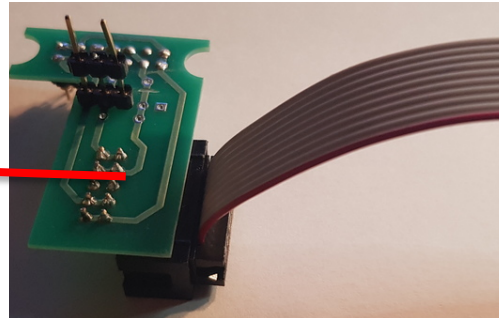

Mount board installed

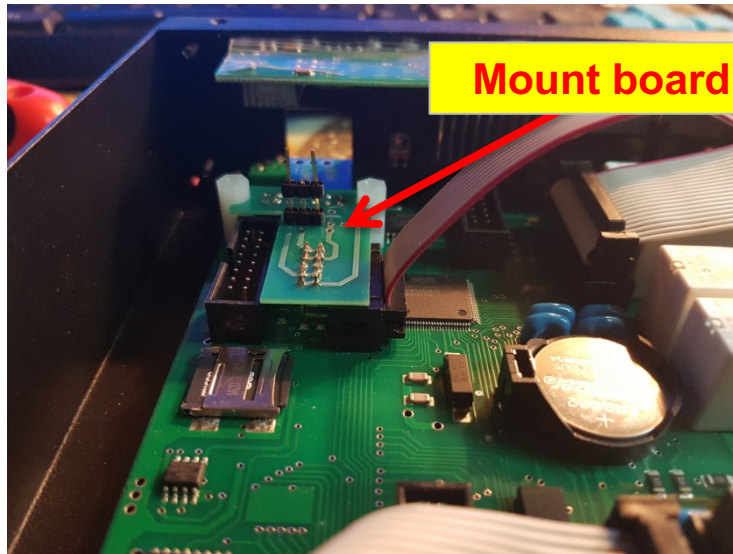

Put Ethernet main unit to the mount board by gently pulling side corner of PCB above

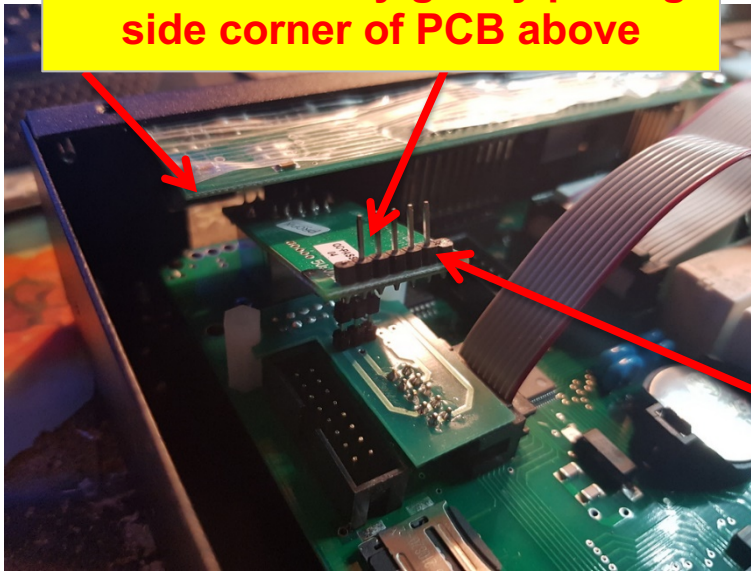

Align pins of the main unit and the mount board inline

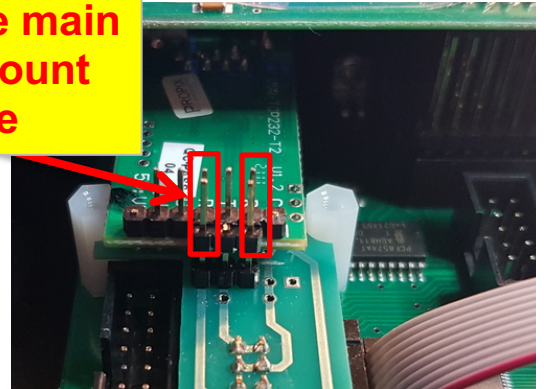
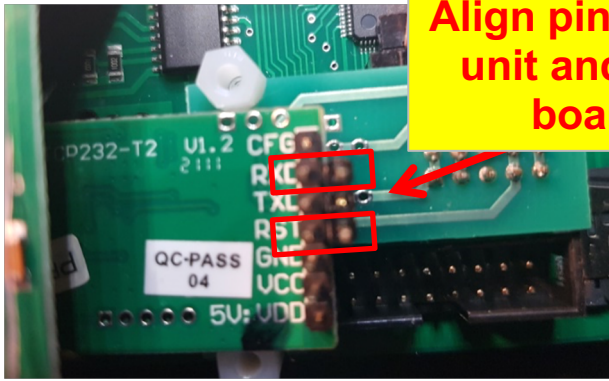

Carefully plug connection cable's asymmetrical connector to connect both main and connection units

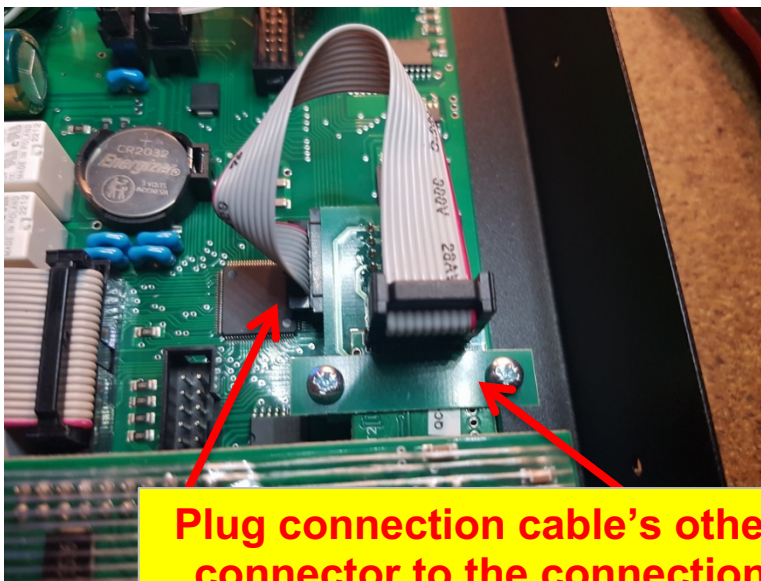
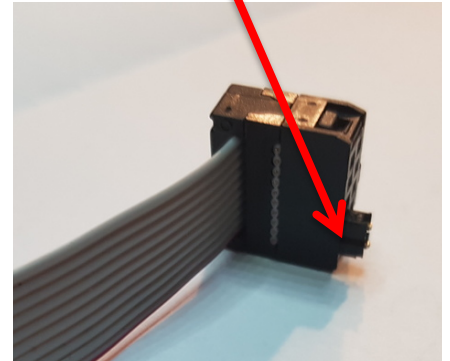

Plug connection cable's other side connector to the connection unit and screw gently top mount bar

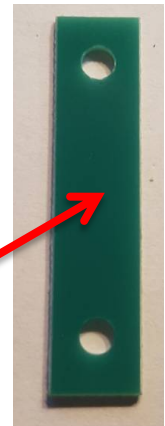

Put on and screw the cover.

Configuration

The Ethernet module is configured by controller's menu. After connecting the LAN cable between computer and controller the IP address is assigned via DHCP. To check assigned IP address go to the SET ETHERNET menu and press arrow right to start checking process:

```
SET ETHERNET
IP: CHECKING...
```

After a while proper address appear (example here):

```
SET ETHERNET
IP: 192.168.0.33
```

To communicate with controller via LAN cable user must choose ETH mode at MOTOR CONFIGURATION menu.

To reset Ethernet module simply go to the menu and:

```
SET ETHERNET
RESET ETHERNET: ON
```

The Ethernet module goes to the default presets.

By default, the module is set in DHCP mode, but after entering the configuration website [password: admin, login: admin], you can change it to a static IP:

Firmware Version: V4017 中文

USR
-IOT Experts- *Be Honest, Do Best!*

Current Status
Local IP Config
Serial Port
Expand Function
Misc Config
Reboot

parameter

IP type:

Static IP: . . .

Submask: . . .

Gateway: . . .

DNS Server: . . .

Help

- **IP type:** StaticIP or DHCP
- **StaticIP:** Module's static ip
- **Submask:** usually 255.255.255.0
- **Gateway:** Usually router's ip address
- **DNS IP:** DNS gateway or Router's IP

Copyright © Jinan USR IOT Technology Limited. All Rights Reserved website: www.usriot.com

Remember to change password!

CCM - CURRENT CONTROL MODULE

Installation of the CCM module in the MD-01

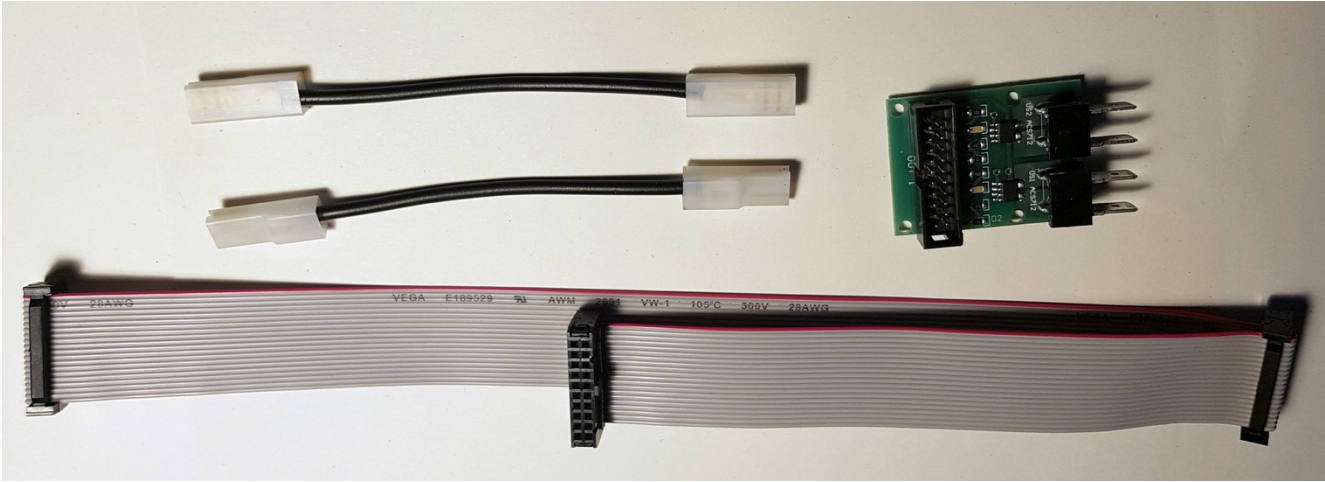

A complete set

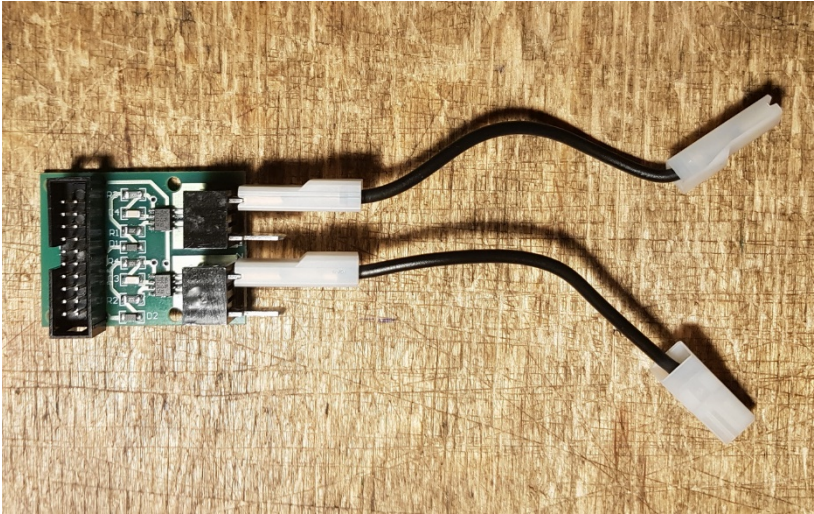

CCM module

Unscrew the screws that fix the top cover of the controller. Remove the cover.

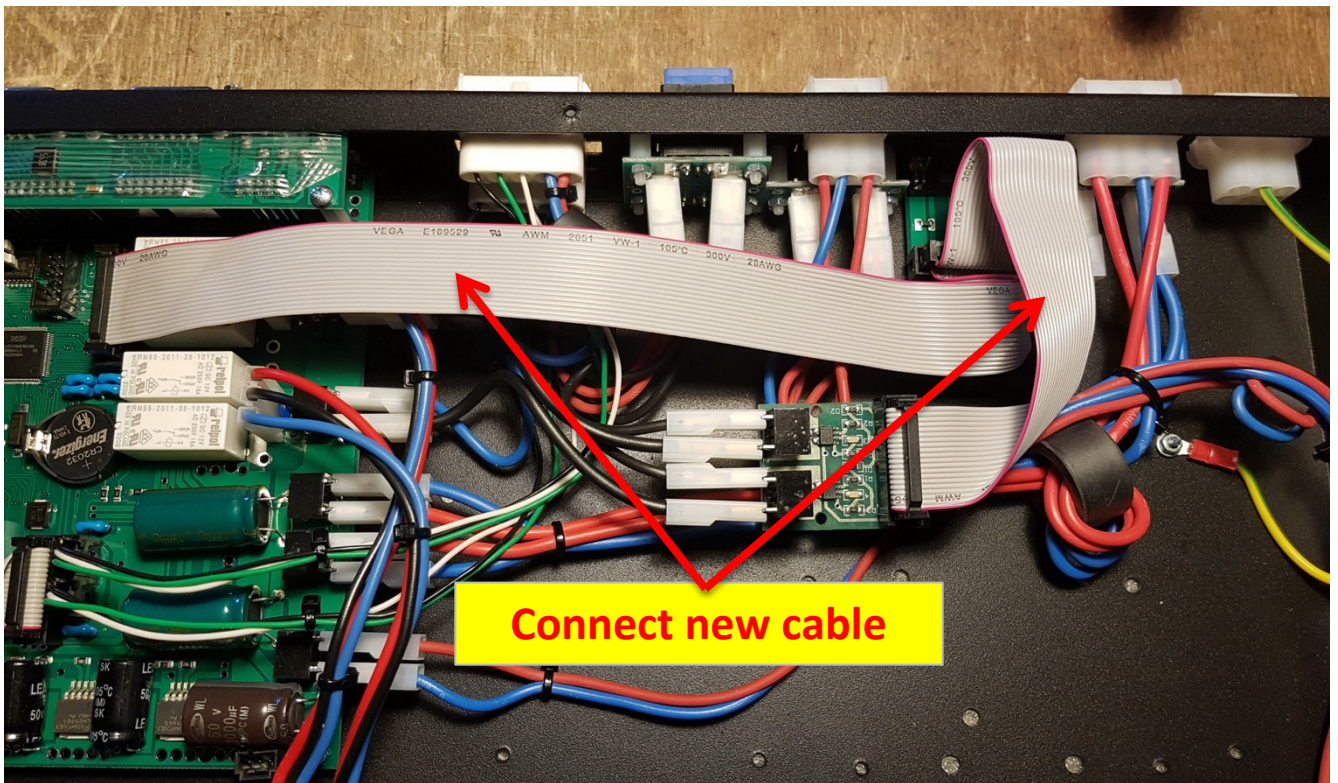
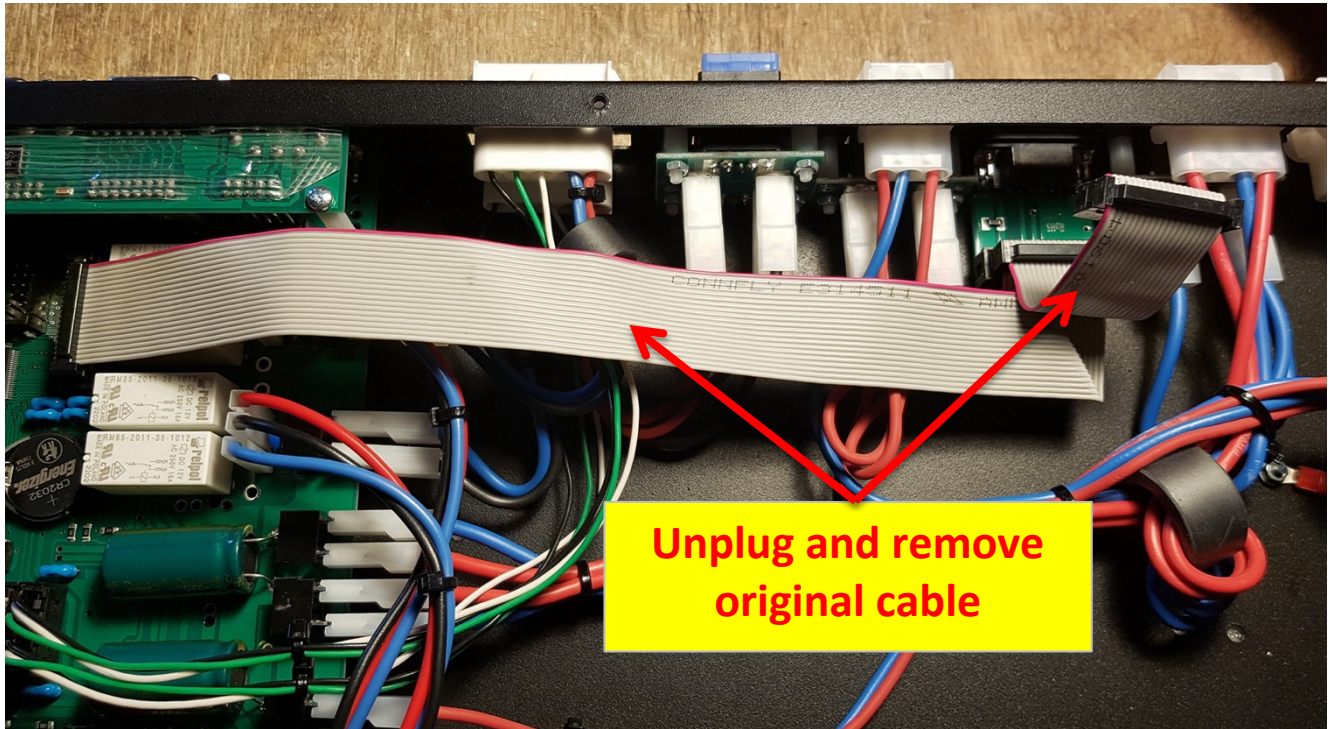

Then follow installation steps of MD-02 CCM module (below).

Secure the stable position of the CCM module to prevent any contact or short circuit with the components and the controller housing. Put on and screw the cover.

Installation of the CCM module in the MD-02

Unscrew the screws that fix the top cover of the controller. Remove the cover.

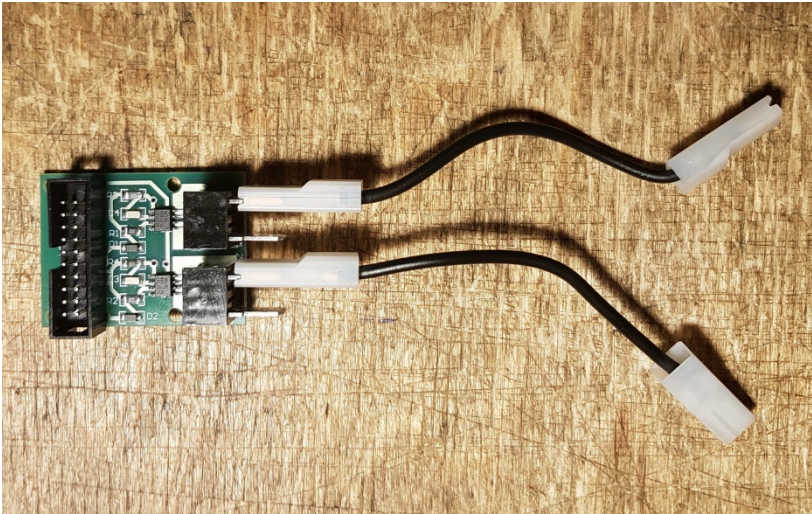

CCM module

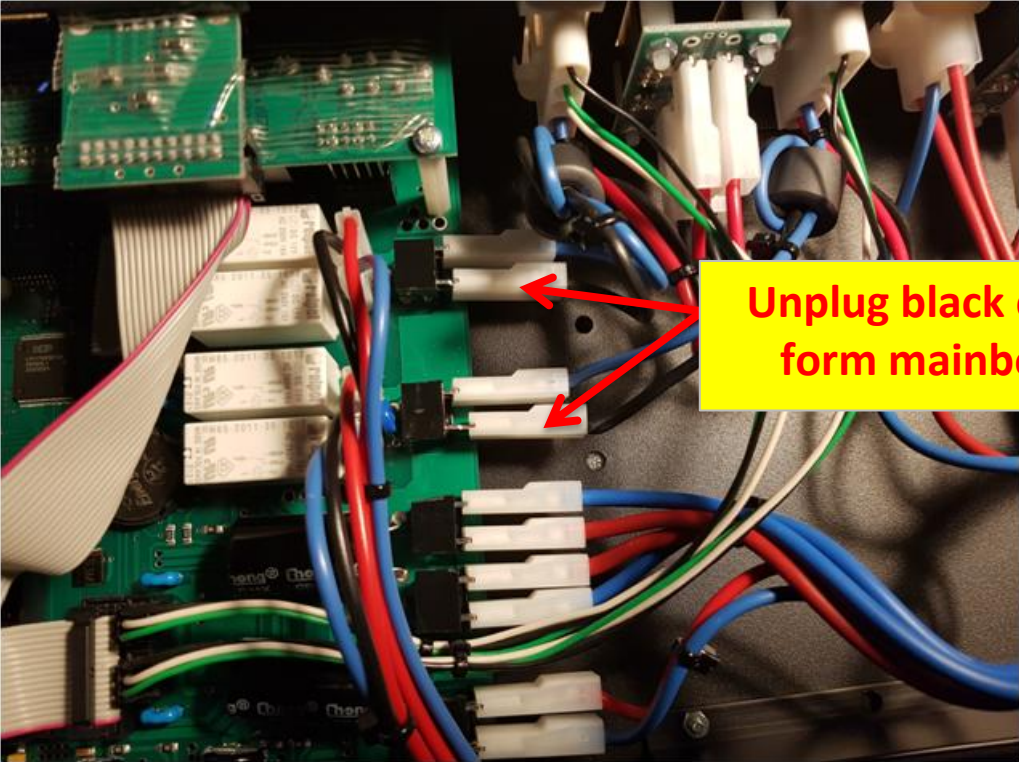

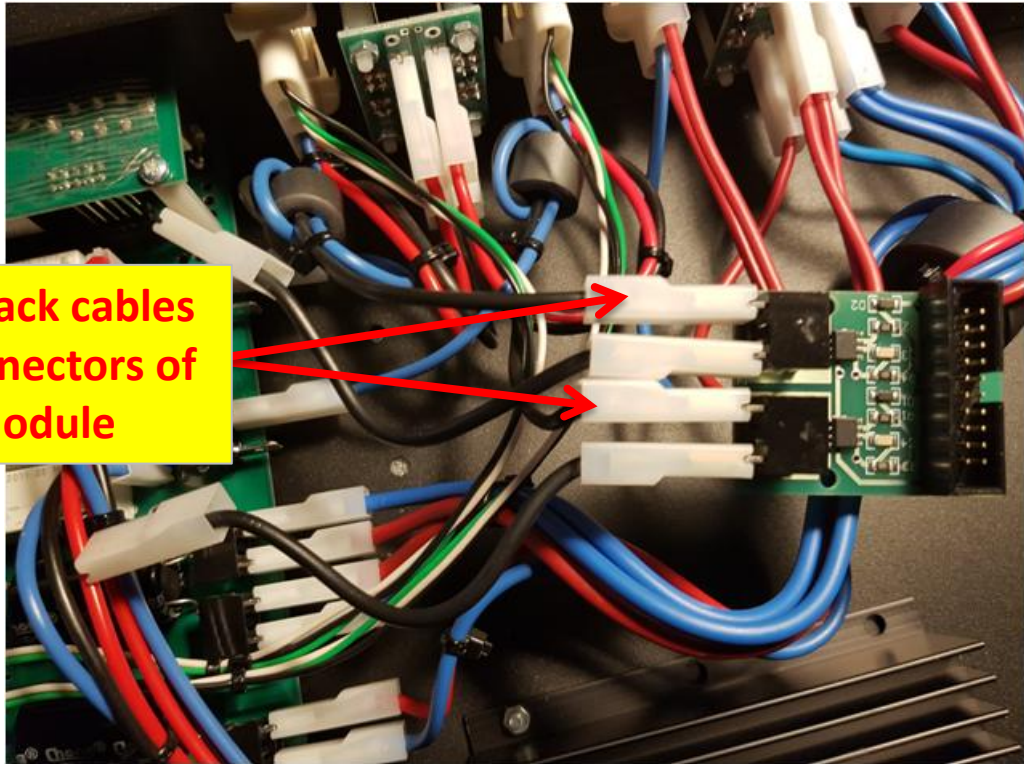

**Connect black cables
to free connectors of
CCM module**

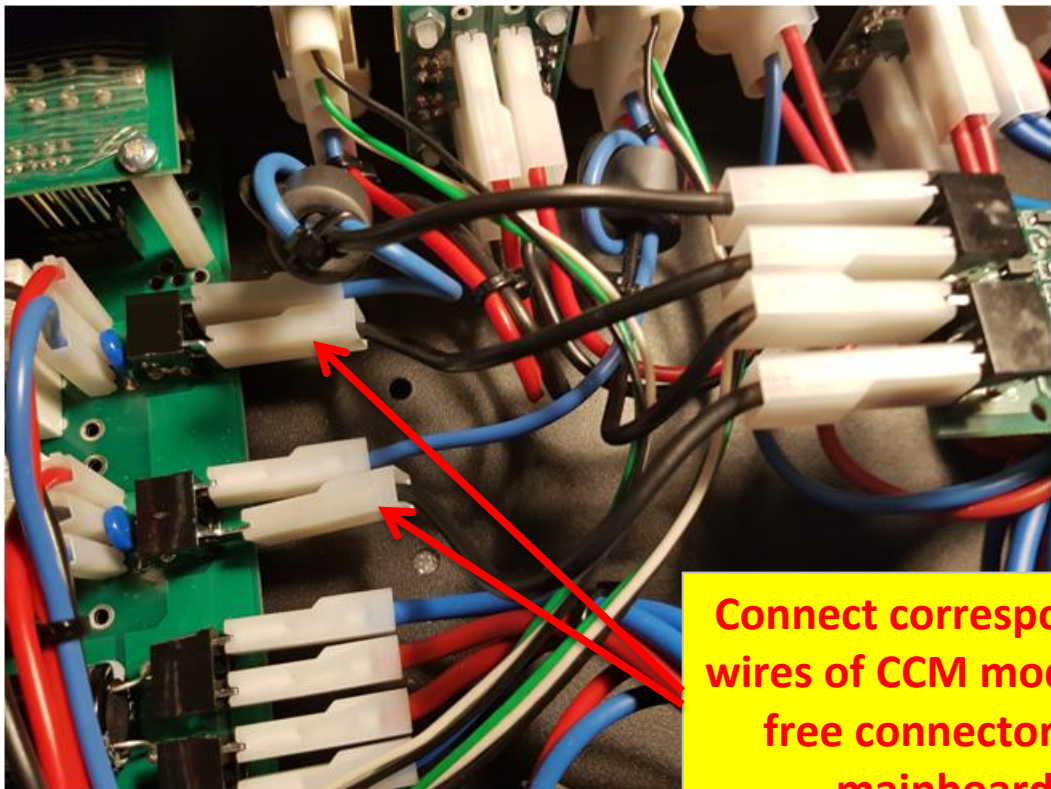

**Connect corresponding
wires of CCM module to
free connectors of
mainboard**

**Connect harness
between the CCM and
the HR module**

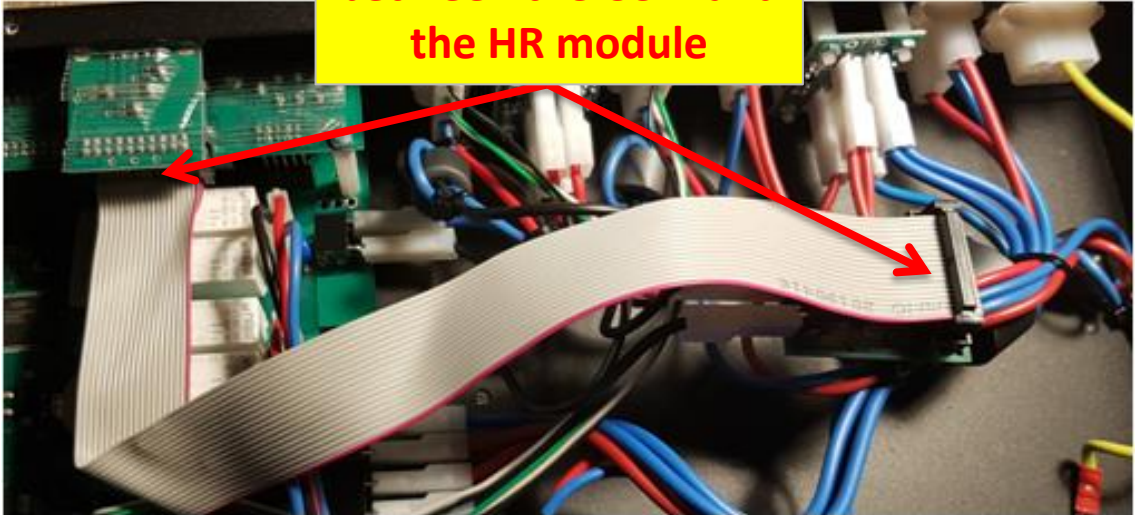

Secure the stable position of the CCM module to prevent any contact or short circuit with the components and the controller housing. Put on and screw the cover.

Installation of the CCM module in the MD-03

Unscrew the screws that fix the top cover of the controller. Remove the cover.

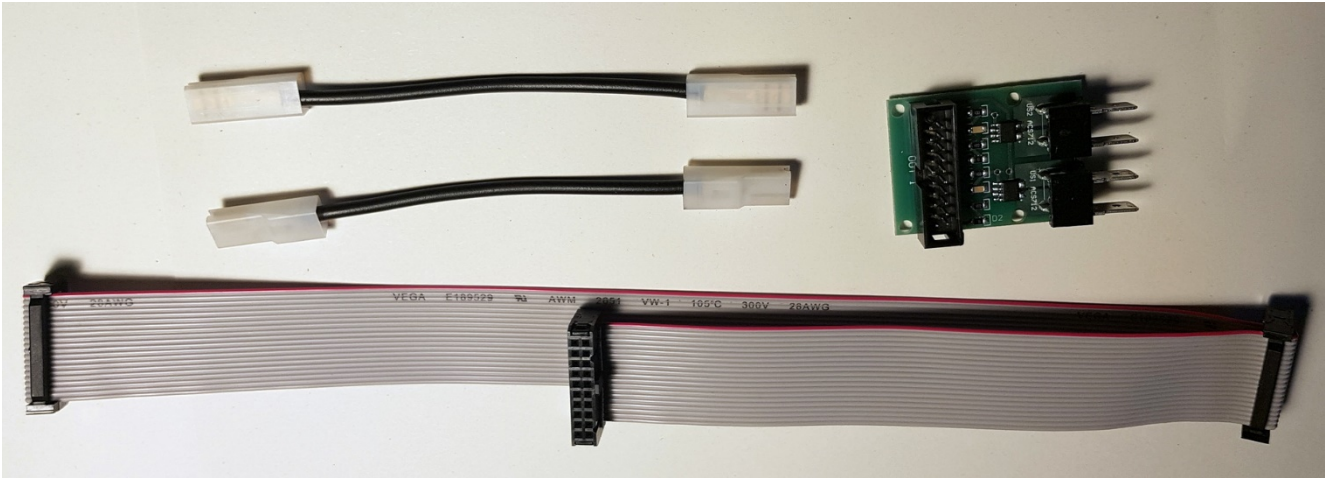

A complete set

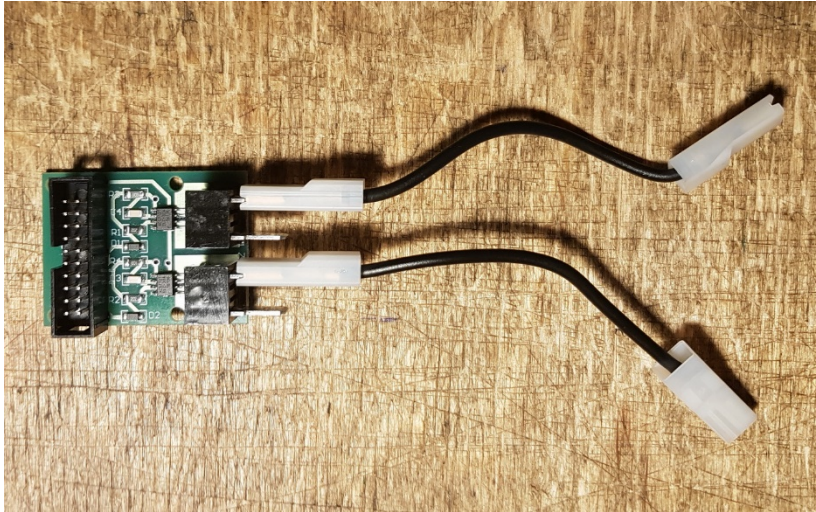

CCM module

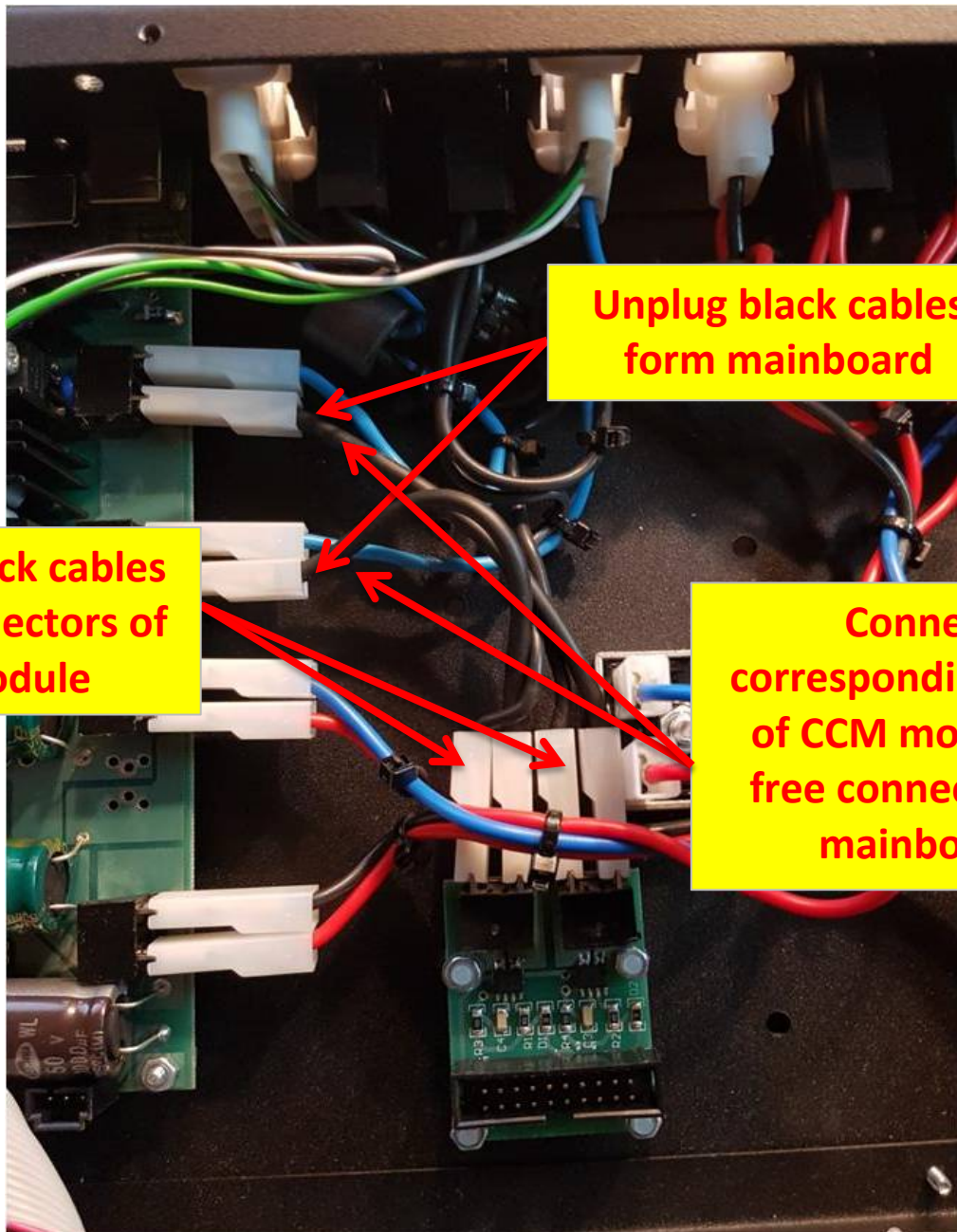

**Unplug black cables
form mainboard**

**Connect black cables
to free connectors of
CCM module**

**Connect
corresponding wires
of CCM module to
free connectors of
mainboard**

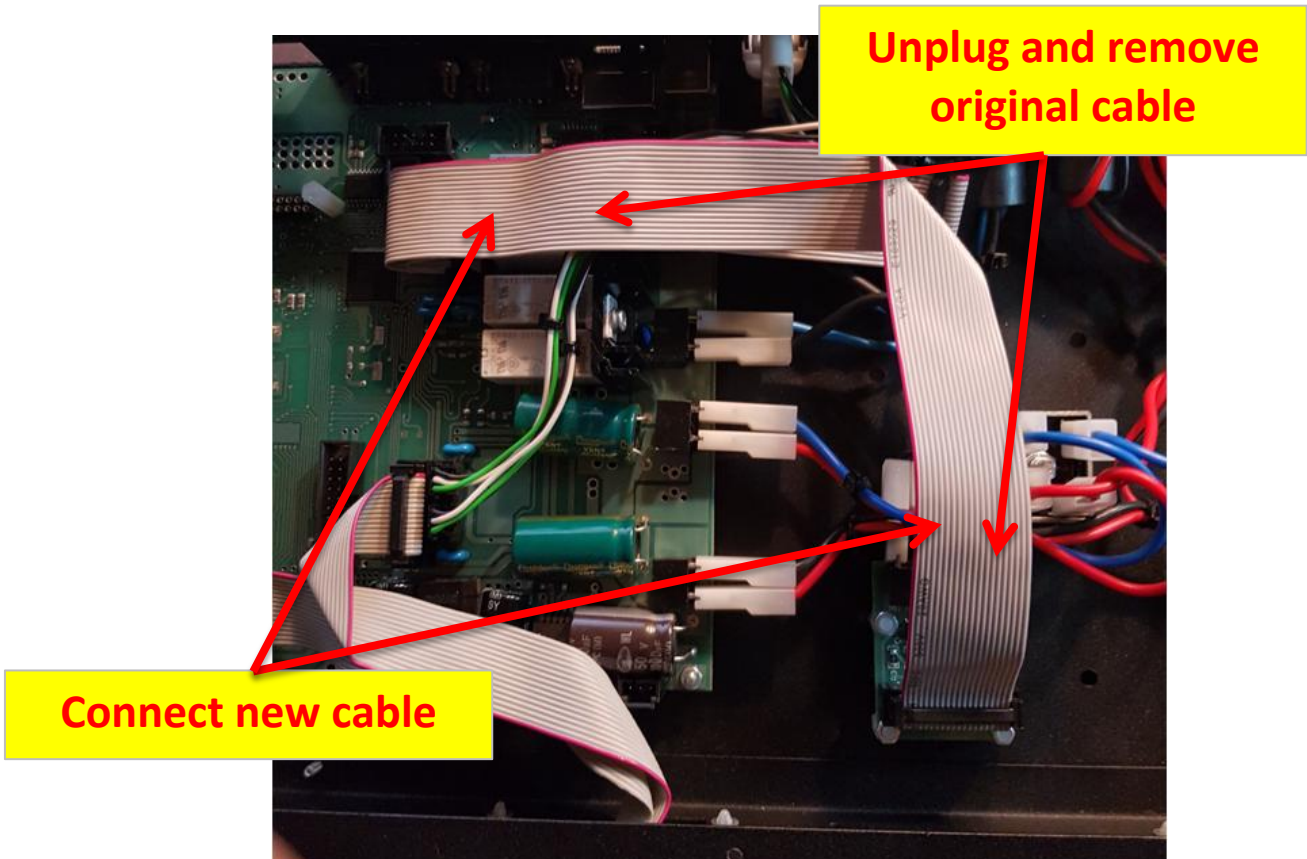

New CCM's cable plugged (controller without HR module)

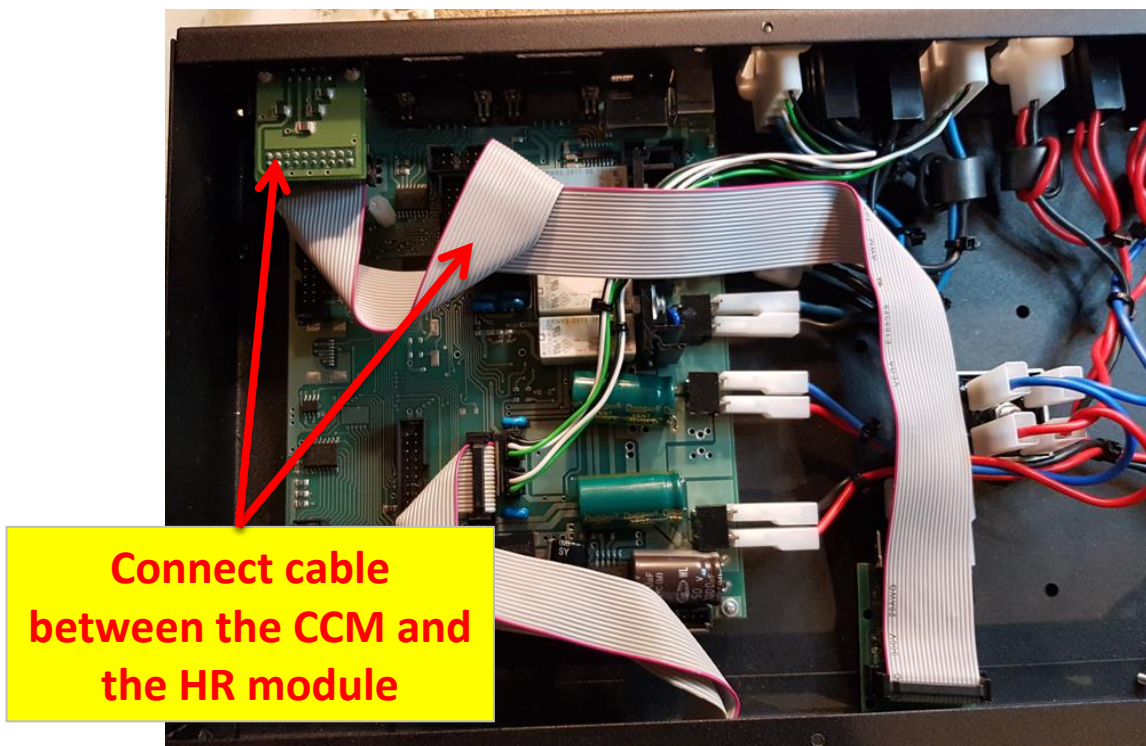

New CCM's cable plugged (controller without HR module)

Secure the stable position of the CCM module to prevent any contact or short circuit with the components and the controller housing. Put on and screw the cover.

Configuration of CCM module

1. Choose **SET MOTOR 1** at the controller menu.
2. Turn on CCM module by setting **CURRENT LIMITER** to **ON**.



```
SET MOTOR 1
CURRENT LIMITER: ON
```

3. Choose value of module's sensor **C. SENSOR** according to installed CCM module.



```
SET MOTOR 1
C. SENSOR: 30A
```

4. Set **MAX CURRENT** value to the maximum motor supply current at which the protection will activate.



```
SET MOTOR 1
MAX CURRENT: 5.0A
```

5. Set **MAX O/C TIME** as the time after which the protection will activate.



```
SET MOTOR 1
MAX O/C TIME: 500ms
```

6. Repeat steps 1-5 for the second motor.
7. Save settings and leave menu.

Operating CCM module

During the operation of the controller, the CCM module controls the current levels of the motors. It happens in the background.

In case of exceeding the declared values of the maximum current **MAX CURRENT** and/or the **MAX O/C TIME**, the controller, depending on which engine is exceeded, will turn off the power supply in an emergency for about 10 seconds with the following message:



```
EM. STOP! O/CURR. M1  
A1: 0.00 E2: 0.00
```

After 10 seconds of emergency power off, the controller is ready to work automatically. However, the operation of the protection should be important information for the user, and as a consequence, the operation of the rotor, antenna carrier system, cable connections and/or the correction of the **MAX CURRENT** parameter should be verified, if it was set too restrictively. These are key issues for the safety of the rotor and the antenna system, therefore extreme care is suggested both when configuring the CCM module and analysing the system status after the current limit message appears.

After installation the CCM module, the user can observe the value of the motors' current. To activate this function, press the [F2] button once. On the LCD screen, where the rotor position is indicated, the current values of the respective motors will appear. The occurrence of slight fluctuations in current indications during the rotor standstill is a normal situation and results from the internal noise of the measuring sensor. Sample LCD screen during rotor operation:



```
MODE: NORMAL  
A1: 1.4A E2: -2.1A
```

IMP/HR MODULE

User installation

The complete module set includes: main unit and connection cable.

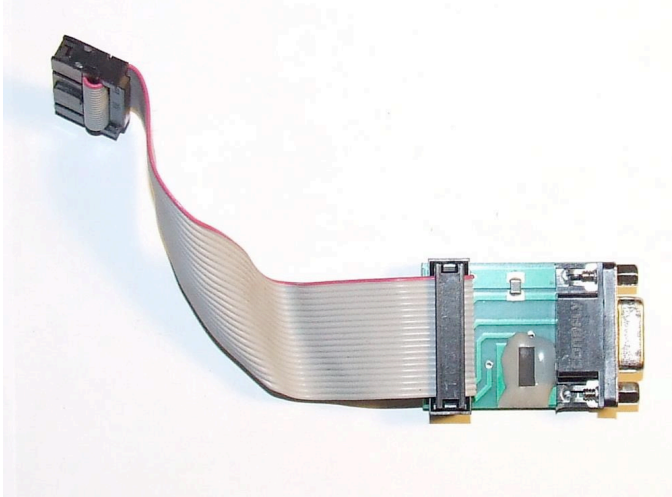

Note: The IMP/HR sensor module is factory connected in the MD-01 and MD-02 controllers.

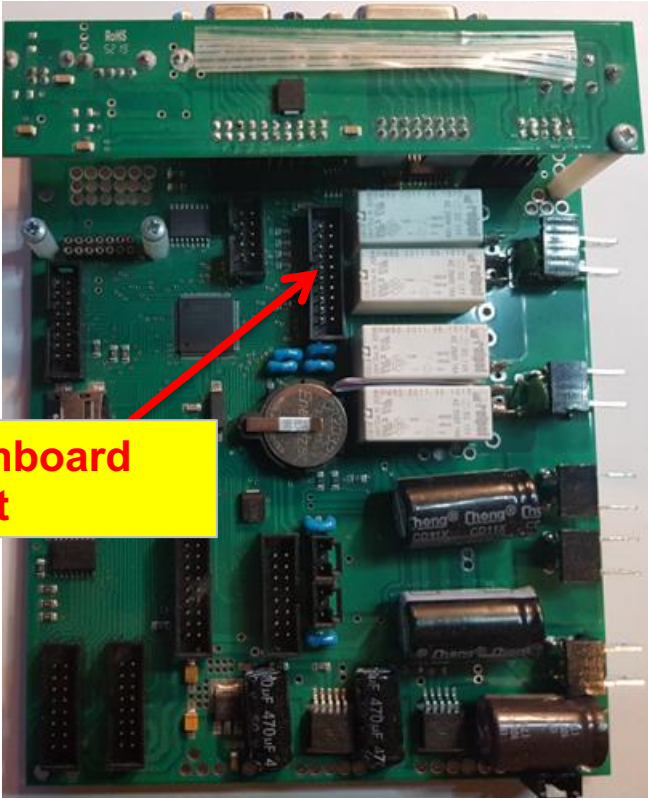

IMP/HR mainboard socket

In the case of the MD-03 controller, the module is installed optionally. Remove the screws securing the top cover of the controller. Open the controller by removing the cover. Locate the IMP/HR module cable socket:

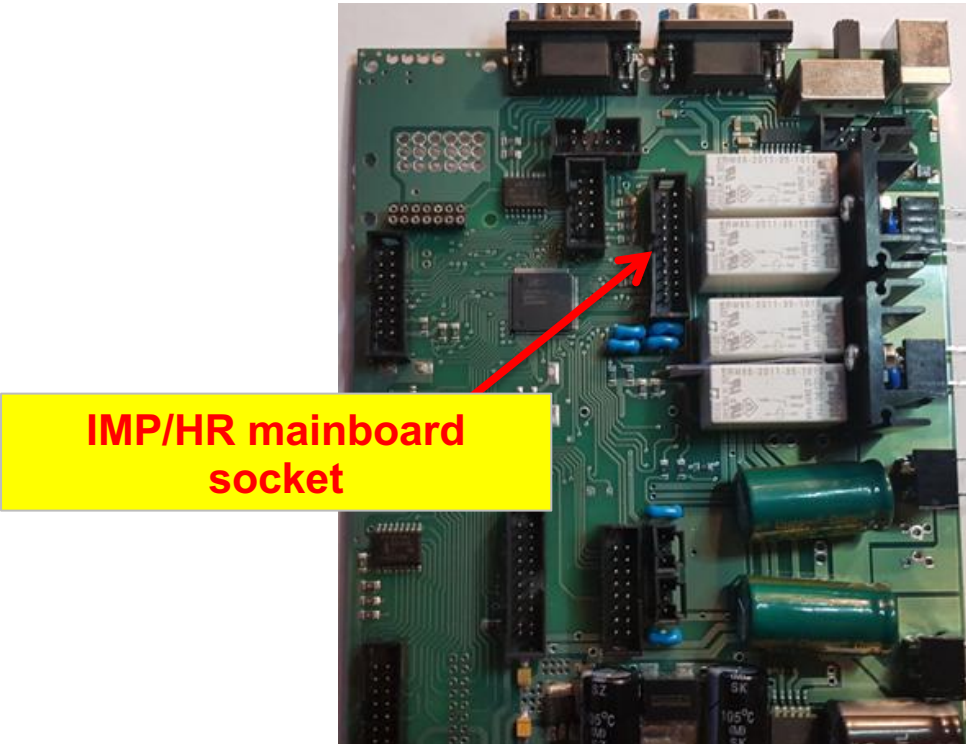

Connect and mount the module according to the instructions below:

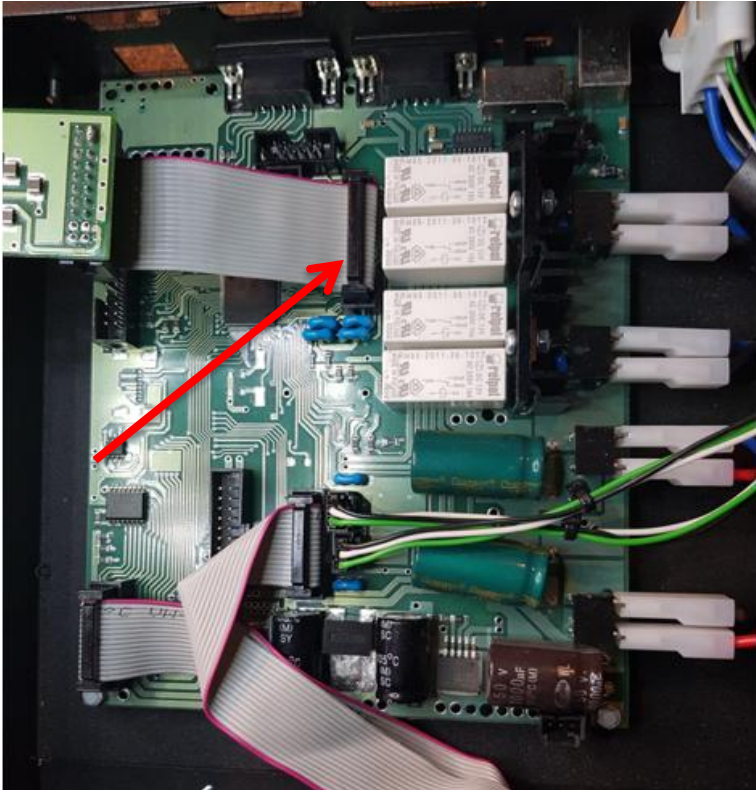

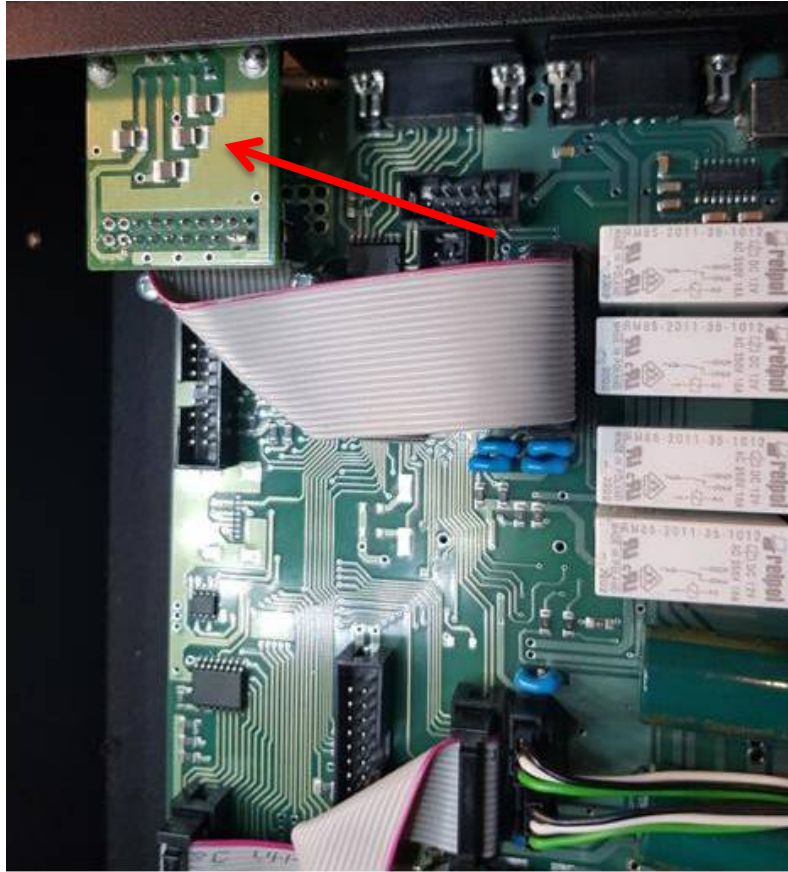

Put on and screw the cover.

COM1 cable for MD-03

User installation

The complete set includes: connection cable.



Open the controller by removing the cover. Locate the COM1 cable socket:

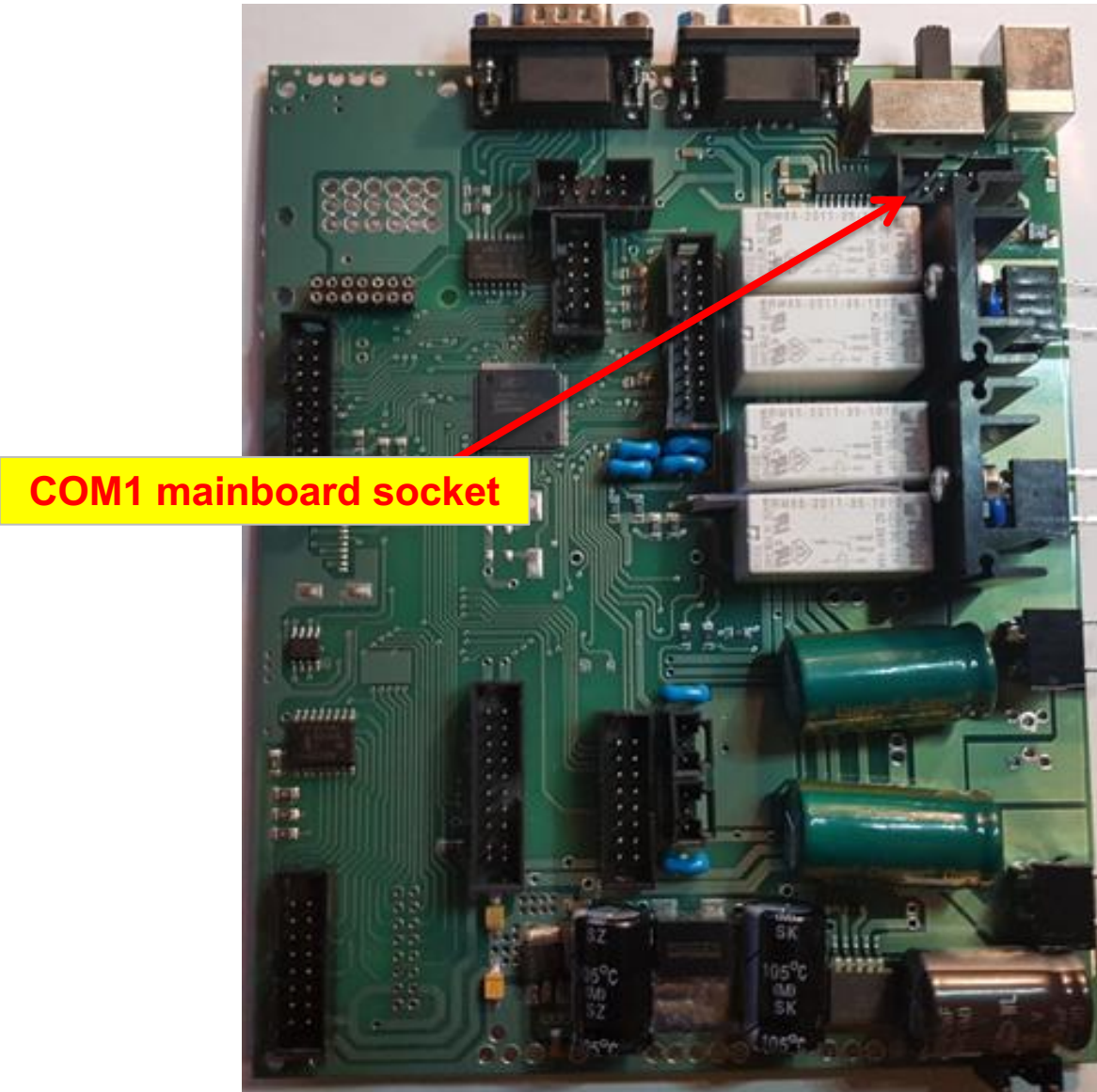

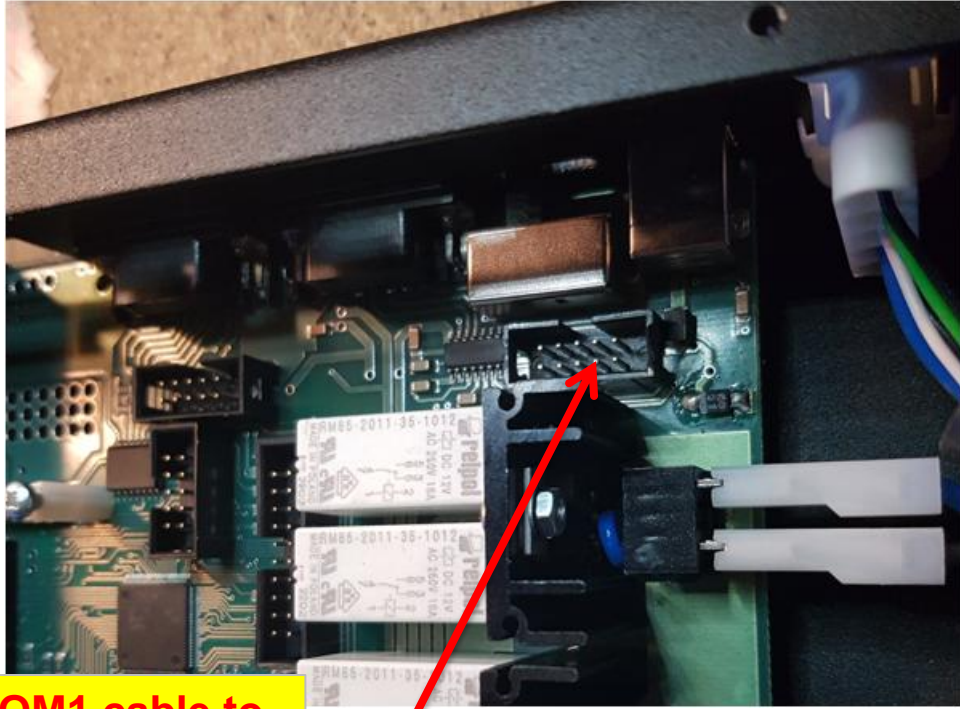

Connect COM1 cable to the mainboard socket



Install COM1 port at the back panel

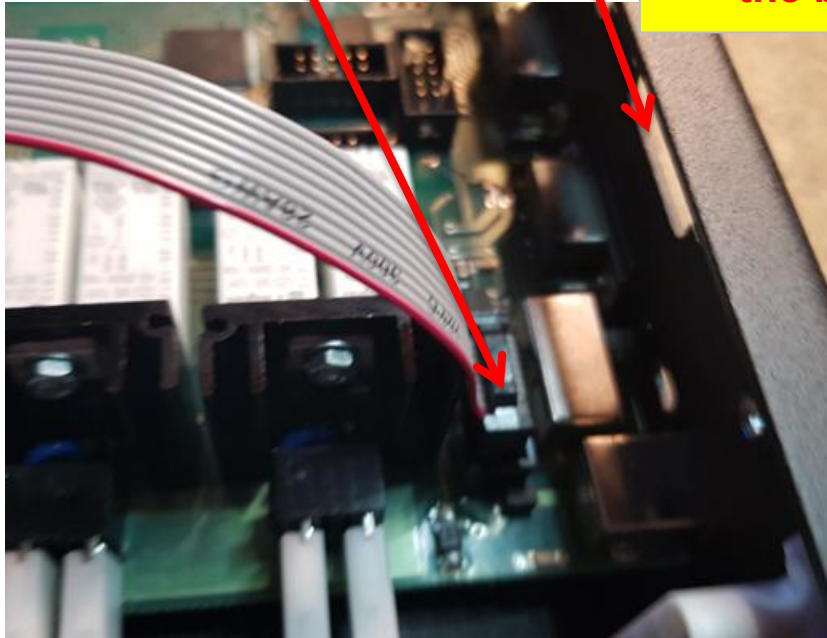

Put on and screw the cover.

FIRMWARE UPDATE

When a firmware is available by SPID you can update the firmware of the MD-0x controller. It is important to install a flash program, we do advise to use Flash-Magic, you can find it at

<http://www.flashmagictool.com/download.html&d=FlashMagic.exe>

Note: A firmware update file will be available at our web-site

Update Step by step:

1. Turn MD-0x device off
2. Set switch to position OFF (back panel of MD-0x)
3. Connect serial Sub-D 9-pol. cable to COM 0 at MD-0x and to serial port PC
4. Turn on MD-0x
5. Start Flash Magic
6. Now Choose from menu options->advanced options, page Hardware Config and set options as on the screen shot below.
7. Close with OK and you will come back in the main screen.

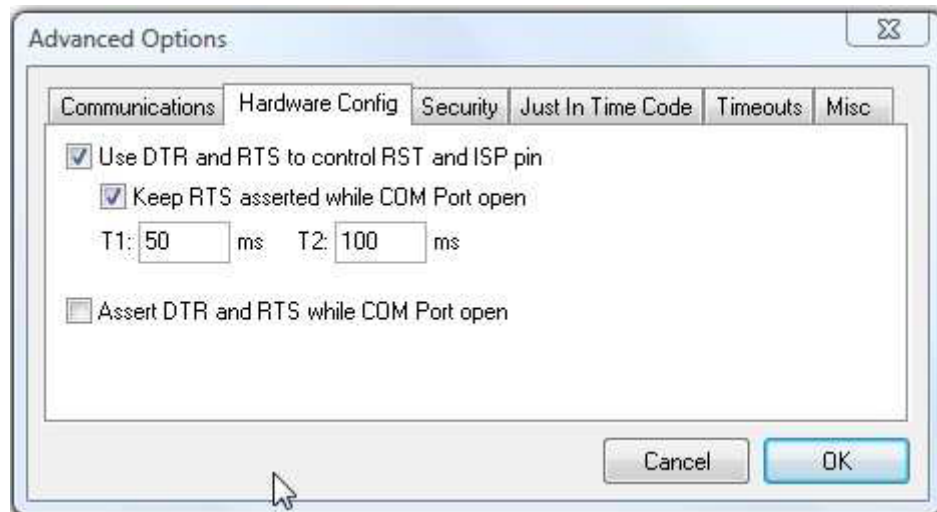

Back in the Main Screen:

1. Select Device: LPC1769
2. Select COM port which is in use at your PC
3. Select firmware file at your Hard Disk
4. Rest of parameters as screen shot below

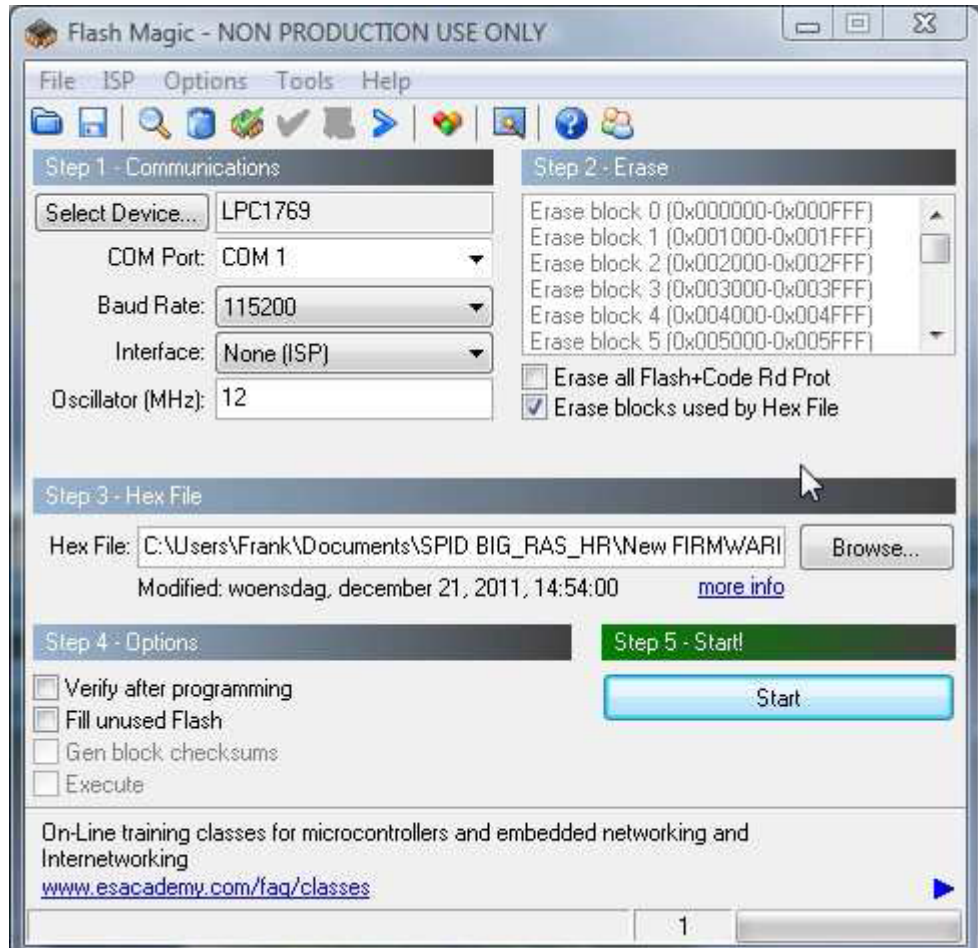

5. Click Start button to start update firmware, if all is setup ok, the LCD screen at the MD-0x turns Off during update, when update is done the screen will light up again.
6. Turn off the driver MD-0x after update finished
7. Set switch to position PR (back panel of MD-0x)
8. Turn MD-0x on
9. New Firmware is installed and MD-0x is ready to use.